

# Dell PowerEdge VRTX Enclosure

## Owner's Manual

## Notes, cautions, and warnings

 **NOTE:** A NOTE indicates important information that helps you make better use of your product.

 **CAUTION:** A CAUTION indicates either potential damage to hardware or loss of data and tells you how to avoid the problem.

 **WARNING:** A WARNING indicates a potential for property damage, personal injury, or death.

© 2014 – 2018 Dell Inc. or its subsidiaries. All rights reserved. Dell, EMC, and other trademarks are trademarks of Dell Inc. or its subsidiaries. Other trademarks may be trademarks of their respective owners.

# Contents

<b>1 About your system.....</b>	<b>8</b>
Introduction.....	8
Terms used in the document.....	8
System overview.....	9
Server module and hard drive numbering — tower mode.....	10
Server module and hard drive numbering — rack mode.....	14
Front panel features and indicators.....	18
KVM features.....	20
Hard drive indicator patterns.....	20
LCD module.....	21
Back panel features and indicators.....	24
Power supply unit indicators.....	25
Blower module indicators.....	26
I/O module indicators.....	27
CMC indicators.....	28
CMC features.....	28
CMC fail-safe mode.....	29
Configuration wizard.....	29
System messages.....	30
LCD messages.....	30
Documentation matrix.....	30
Quick Resource Locator.....	31
<b>2 Initial system configuration.....</b>	<b>32</b>
Before you begin.....	32
Initial setup sequence.....	32
Logging in to the CMC.....	33
<b>3 Configuring enclosure components.....</b>	<b>34</b>
Fabric A.....	34
Fabrics B and C.....	34
I/O module and PCIe mezzanine card configuration guidelines.....	34
Supported I/O modules.....	35
Configuring network settings for the I/O module.....	35
Mapping PCIe expansion slots.....	35
Managing PCIe slots.....	36
Managing chassis storage.....	36
<b>4 Installing enclosure components.....</b>	<b>38</b>
Recommended tools.....	39
Front bezel (optional).....	39
Installing the optional front bezel.....	39

Removing the optional front bezel.....	40
System feet—tower mode.....	40
Removing the system feet.....	40
Installing the system feet.....	41
Wheel assembly (optional)—tower mode.....	41
Installing the optional wheel assembly.....	41
Removing the optional wheel assembly.....	43
System cover.....	44
Opening the system.....	44
Closing the system.....	45
Inside the system.....	45
Hard drives.....	46
Removing a 2.5 inch hard drive blank.....	47
Installing A 2.5 Inch Hard-Drive Blank.....	47
Removing a 3.5 inch hard drive blank.....	47
Installing a 3.5-inch hard drive blank.....	48
Removing a hot-swap hard drive.....	48
Installing a hot-swap hard drive.....	49
Removing a hard drive from a hard drive carrier.....	49
Installing a hard drive into a hard drive carrier.....	51
Server modules.....	51
Removing a server module.....	52
Configuring a server module.....	53
Installing a server module.....	54
Server module partitions.....	54
Removing the server module partitions.....	55
Installing the server module partitions.....	56
Power supply units.....	58
Power supply unit blanks.....	58
Removing a power supply unit.....	59
Installing a power supply.....	61
Cooling shroud.....	62
Removing the cooling shroud.....	62
Installing the cooling shroud.....	63
Cooling fans.....	63
Removing a cooling fan.....	63
Installing a cooling fan.....	64
Cooling fan assembly.....	64
Removing the cooling fan assembly.....	64
Installing the cooling fan assembly.....	65
Blower modules.....	66
Removing a blower module.....	66
Installing a blower module.....	67
Removing the blower module bay.....	67
Installing the blower module bay.....	68

I/O module.....	69
Removing the I/O module.....	69
Installing the I/O module.....	69
Optical drive (optional).....	70
Removing the optional optical drive.....	70
Installing the optional optical drive.....	71
CMC cards.....	72
CMC card indicators.....	72
Removing a CMC card.....	73
Installing a CMC card.....	74
PCIe cage.....	74
Removing the PCIe cage door.....	74
Installing the PCIe cage door.....	75
Removing the PCIe cage.....	75
Installing the PCIe cage.....	77
Expansion cards.....	78
Expansion card installation guidelines.....	78
Expansion card operational power status.....	79
PCIe slot indicators.....	80
Removing a low profile expansion card.....	81
Installing a low profile expansion card.....	82
Removing the low profile expansion card divider unit.....	83
Installing the low profile expansion card divider unit.....	84
Removing a full height expansion card.....	85
Installing a full height expansion card.....	86
Removing the full-height expansion card divider unit.....	87
Installing the full height expansion card divider unit.....	88
Removing the expansion card riser.....	89
Installing the expansion card riser.....	90
Double-wide GPGPU card (optional).....	90
Removing a double-wide GPGPU card.....	91
Installing an optional double-wide GPGPU card.....	92
Integrated storage controller cards.....	94
Storage controller operational power status.....	94
Storage controller indicators.....	96
Removing an integrated storage controller card.....	97
Installing an integrated storage controller card.....	98
Shared PERC 8 External card.....	99
System battery.....	100
Replacing the system battery.....	100
System top and base covers.....	101
Removing the system top and base covers.....	101
Installing the system top and base covers.....	102
Mounting ears.....	103
Removing the mounting ears.....	103

Installing the mounting ears.....	104
Replacing the LCD module.....	105
Control panel assembly.....	105
Removing the control panel.....	105
Installing the control panel.....	106
Removing the control panel board.....	107
Installing the control panel board.....	108
Backplane expander boards.....	109
Removing a backplane expander board.....	109
Installing a backplane expander board.....	110
Hard drive backplane.....	111
Removing the hard drive backplane.....	111
Installing the hard drive backplane.....	113
Power distribution board.....	114
Removing the power distribution board.....	114
Installing the power distribution board.....	116
System board.....	116
Removing the system board.....	116
Installing the system board.....	118
Power pass-through board.....	118
Removing the power pass-through board.....	118
Installing the power pass-through board.....	120
Midplane.....	120
Removing the midplane.....	120
Installing the midplane.....	122
<b>5 Converting the system from tower mode to rack mode.....</b>	<b>124</b>
Safety instructions.....	124
Preparing a system for conversion from tower mode to rack mode.....	124
Installing the enclosure in a rack.....	128
<b>6 Troubleshooting your system.....</b>	<b>129</b>
Safety first—for you and your system.....	129
Responding to a systems management alert message.....	129
Troubleshooting external connections.....	129
Troubleshooting a damaged enclosure.....	129
Troubleshooting enclosure components.....	130
Troubleshooting a wet enclosure.....	130
Troubleshooting power supply units.....	131
Troubleshooting power supply unit mismatch.....	131
Troubleshooting blower modules.....	131
Troubleshooting the system battery.....	132
Troubleshooting cooling problems.....	132
Troubleshooting cooling fans.....	132
Troubleshooting an optical drive.....	133
Troubleshooting a storage controller.....	133

Troubleshooting hard drives.....	133
Troubleshooting expansion cards.....	134
Troubleshooting the I/O module.....	135
<b>7 System board connectors.....</b>	<b>136</b>
<b>8 Technical specifications.....</b>	<b>139</b>
Enclosure dimensions and weight — Tower.....	139
Enclosure dimensions and weight — Rack.....	139
Server module specifications.....	140
Expansion bus specifications.....	140
Power specifications.....	140
Drive specifications.....	141
Chassis Management Controller specifications.....	141
Enclosure control panel specifications.....	141
I/O Module specifications.....	141
Environmental specifications.....	141
Expanded operating temperature.....	143
<b>9 Getting help.....</b>	<b>145</b>
Contacting Dell.....	145
Quick Resource Locator.....	145

# About your system

Topics:


- [Introduction](#)
- [System overview](#)
- [Front panel features and indicators](#)
- [Back panel features and indicators](#)
- [Configuration wizard](#)
- [System messages](#)
- [LCD messages](#)
- [Documentation matrix](#)

## Introduction

This document provides information on the Dell PowerEdge VRTX enclosure.

## Terms used in the document

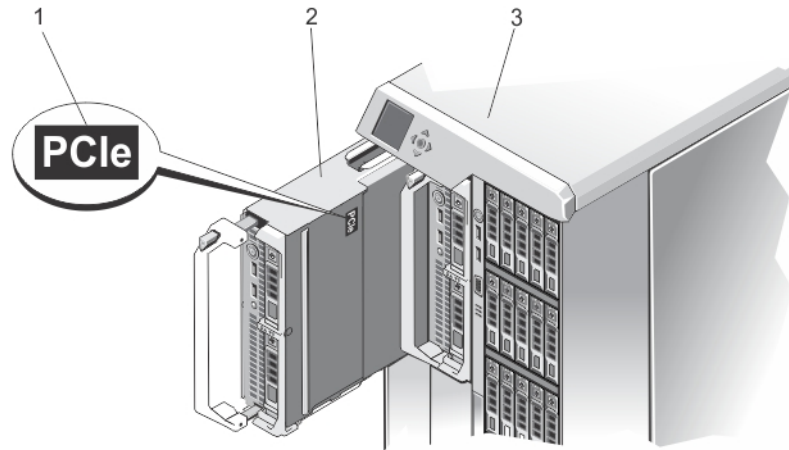
The following table describes the terms used in this document.

Term	Description
Enclosure or chassis	Refers to the PowerEdge VRTX enclosure.
Server module(s)	Refers to server module(s) that are specifically configured for the enclosure. For information about the server modules, see the server module Owner's Manual at <a href="https://www.dell.com/poweredgemanuals">Dell.com/poweredgemanuals</a> .
I/O module	Refers to an Ethernet pass-through module or a switch module installed in the chassis.
PCIe mezzanine card(s)	Server modules configured for the PowerEdge VRTX enclosure have PCIe mezzanine cards installed in Fabric B and C to provide I/O expansion.   <b>NOTE: Ethernet, Fibre Channel, or InfiniBand mezzanine cards are not supported on the PowerEdge VRTX enclosure.</b>
PCIe expansion card(s)	PCIe cards installed in the enclosure provide I/O expansion to the chassis.
Warm plug	A slot is considered warm plug if the server module associated with a component in that slot must be turned off before adding or replacing the component. However, the chassis and the rest of the server modules remain powered on.
Hot swap	A slot in the chassis is considered as hot swap if a component can be replaced or installed in it while the chassis and server modules are powered on.



# System overview

Your system includes up to four half-height server modules, two full-height server modules, or a mix of the server module types. The server modules are specifically configured for the PowerEdge VRTX enclosure, and can be identified by a label marked **PCIe** on the server module.



**Figure 1. Identifying a server module configured for the PowerEdge VRTX enclosure**

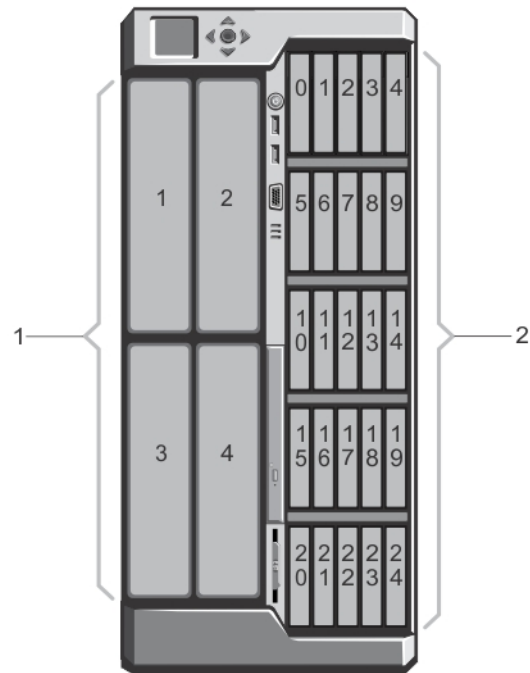
- 1 **PCIe** label on the server module
- 2 server module
- 3 PowerEdge VRTX enclosure

If you install server modules that are not configured for the enclosure, an error message is displayed.

The enclosure supports power supply units, hard drives, Chassis Management Controllers (CMC), blower modules, and an I/O module. These are shared resources for the server modules.

**NOTE:** To ensure proper operation and cooling, all bays in the enclosure must be populated at all times with either a server module or with a blank. Similarly, all empty hard drive slots in the enclosure must be installed with hard drive blanks.

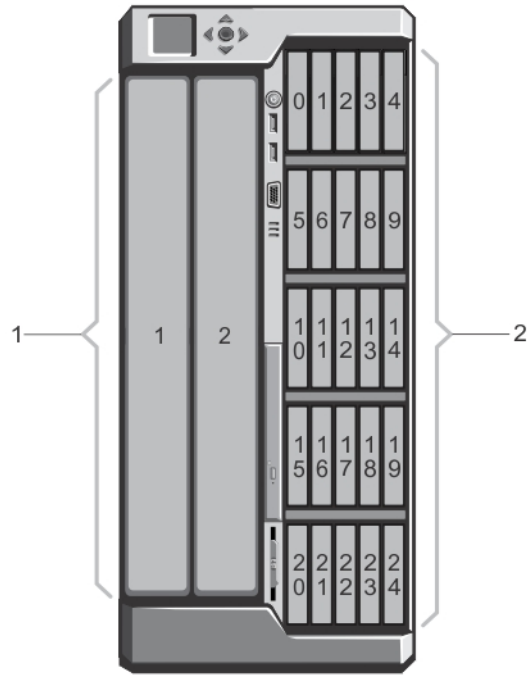
## Server module and hard drive numbering — tower mode



**Figure 2. Half-height server module and hard drive numbering — 2.5-inch hard drive chassis**

1 server module numbering

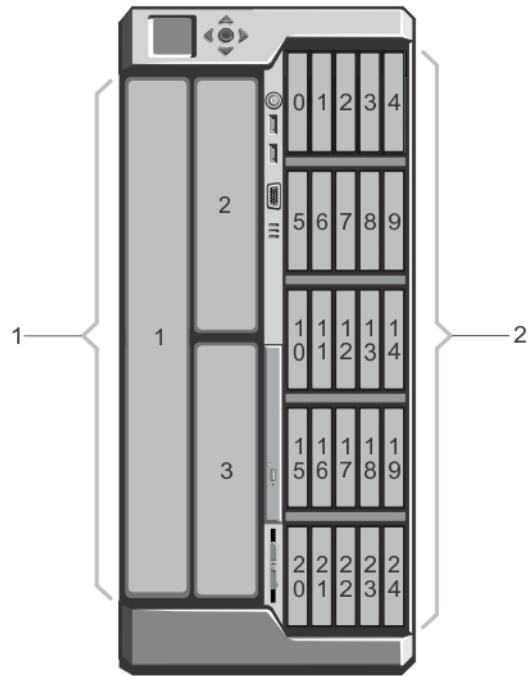
2 hard drive numbering



**Figure 3. Full-height server module and hard drive numbering — 2.5-inch hard drive chassis**

1 server module numbering

2 hard drive numbering



**Figure 4. Server module (half-height and full-height server modules) and hard drive numbering — 2.5-inch hard drive chassis**

1 server module numbering

2 hard drive numbering

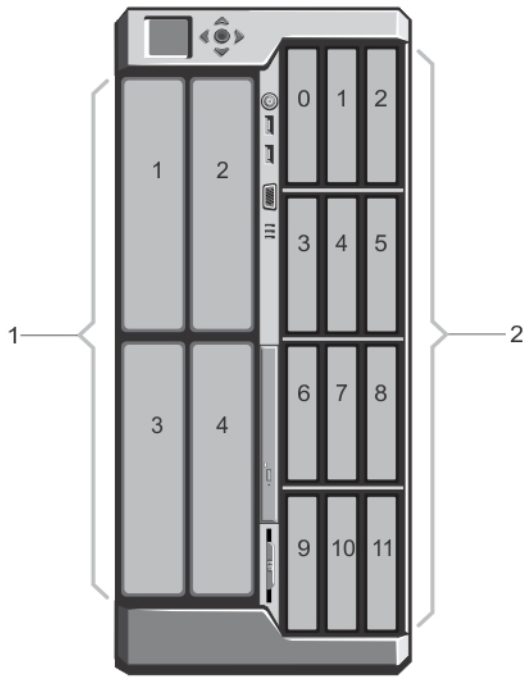


Figure 5. Half-height server module and hard drive numbering — 3.5-inch hard drive chassis

1 server module numbering

2 hard drive numbering

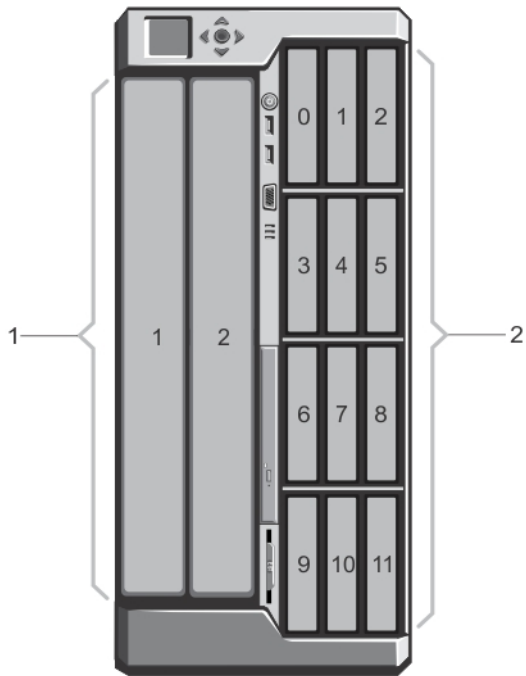
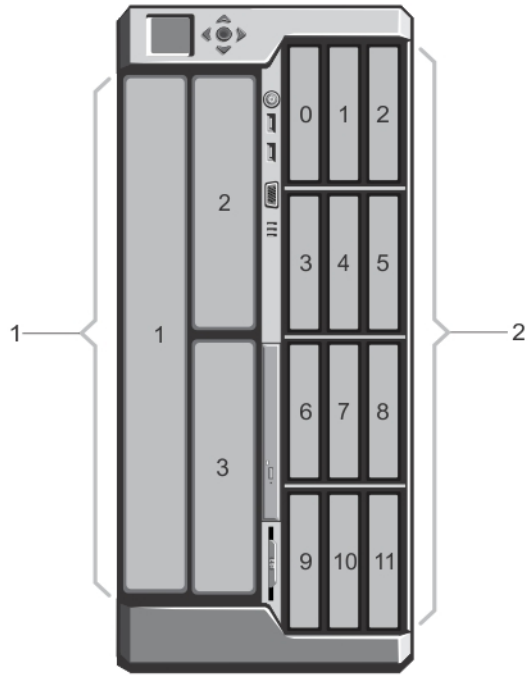


Figure 6. Full-height server module and hard drive numbering — 3.5-inch hard drive chassis

1 server module numbering

2 hard drive numbering

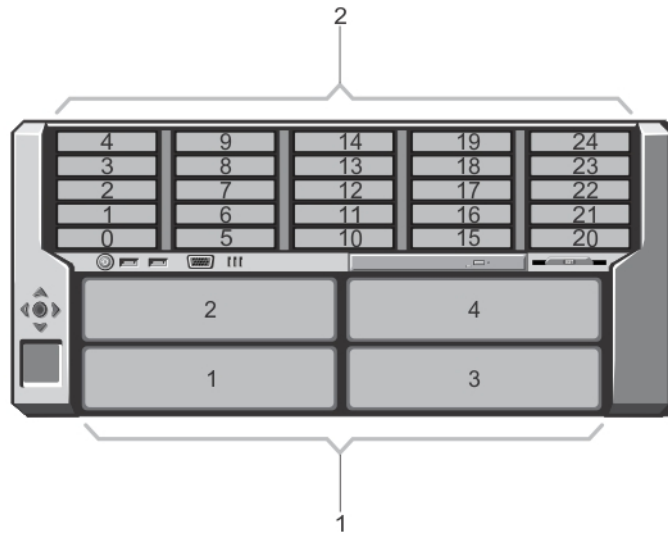


**Figure 7. Server module (half-height and full-height server modules) and hard drive numbering — 3.5-inch hard drive chassis**

1 server module numbering

2 hard drive numbering

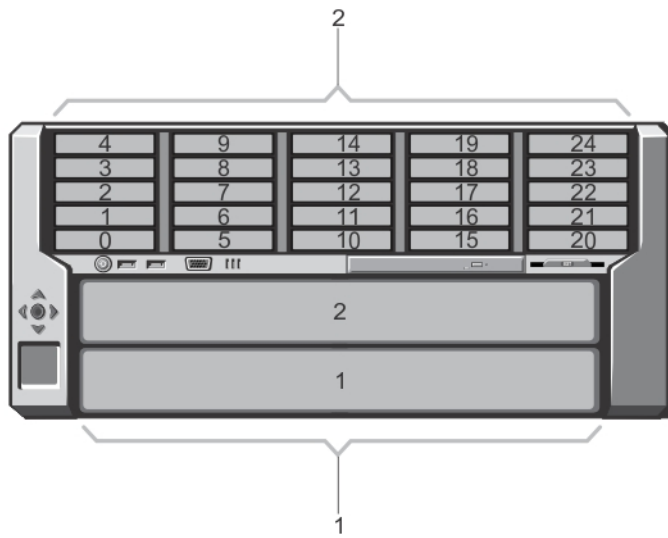
## Server module and hard drive numbering — rack mode



**Figure 8. Half-height server module and hard drive numbering — 2.5-inch hard drive chassis**

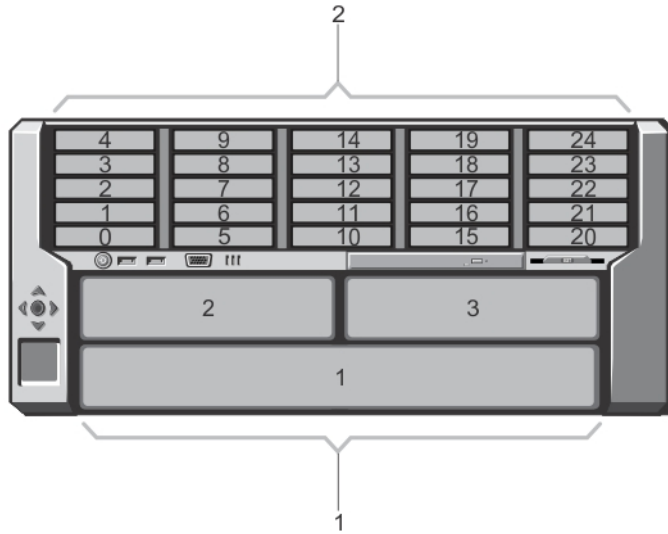
1 server module numbering

2 hard drive numbering

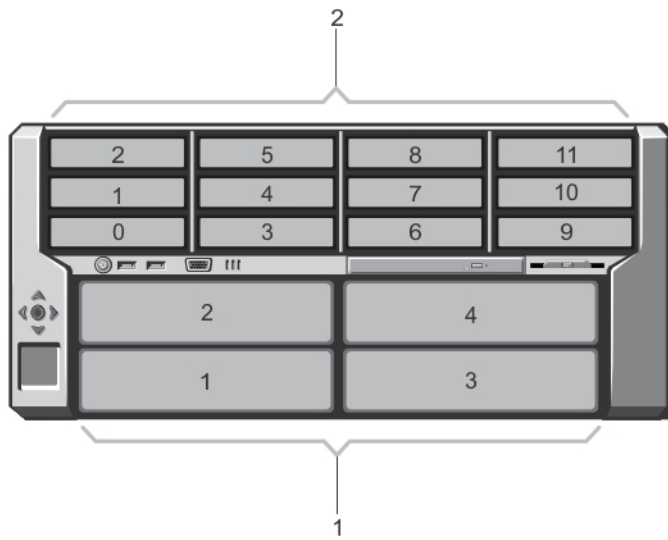


**Figure 9. Full-height server module and hard drive numbering — 2.5-inch hard drive chassis**

- 1 server module numbering
- 2 hard drive numbering

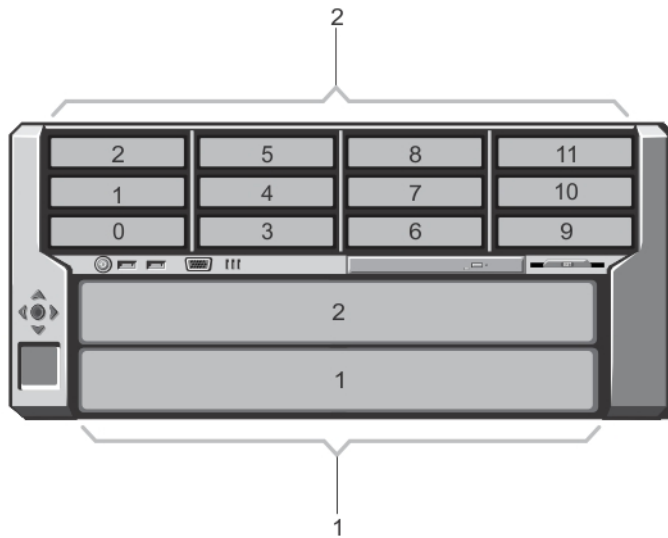


**Figure 10. Server module (half-height and full-height server modules) and hard drive numbering — 2.5-inch hard drive chassis**



**Figure 11. Half-height server module and hard drive numbering — 3.5-inch hard drive chassis**

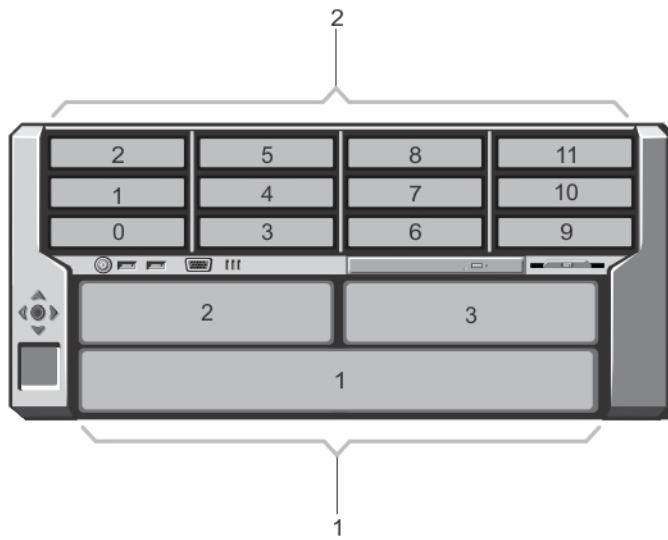
- 1 server module numbering
- 2 hard drive numbering



**Figure 12. Full-height server module and hard drive numbering — 3.5-inch hard drive chassis**

- 1 server module numbering
- 2 hard drive numbering





**Figure 13. Server module (half-height and full-height server modules) and hard drive numbering — 3.5-inch hard drive chassis**

1 server module numbering

2 hard drive numbering

# Front panel features and indicators

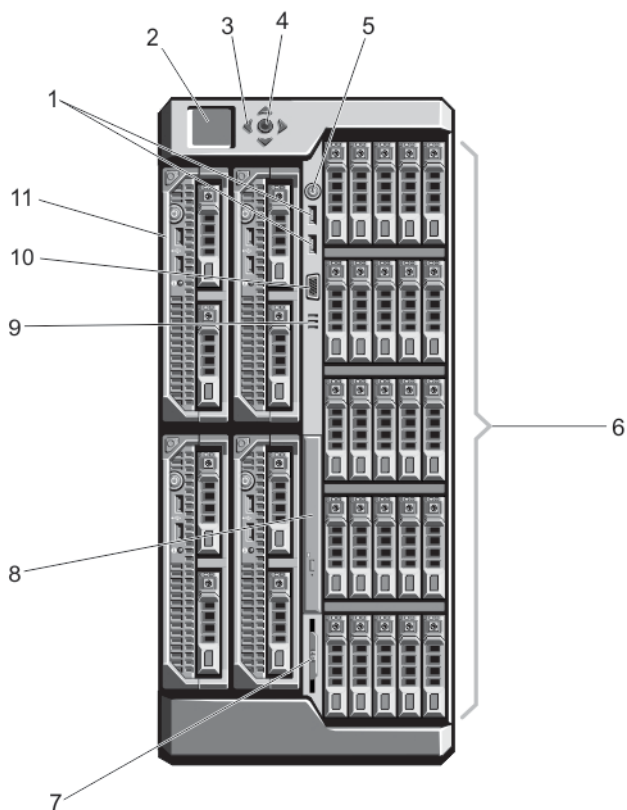


Figure 14. Front panel features and indicators — 2.5-inch hard drive chassis

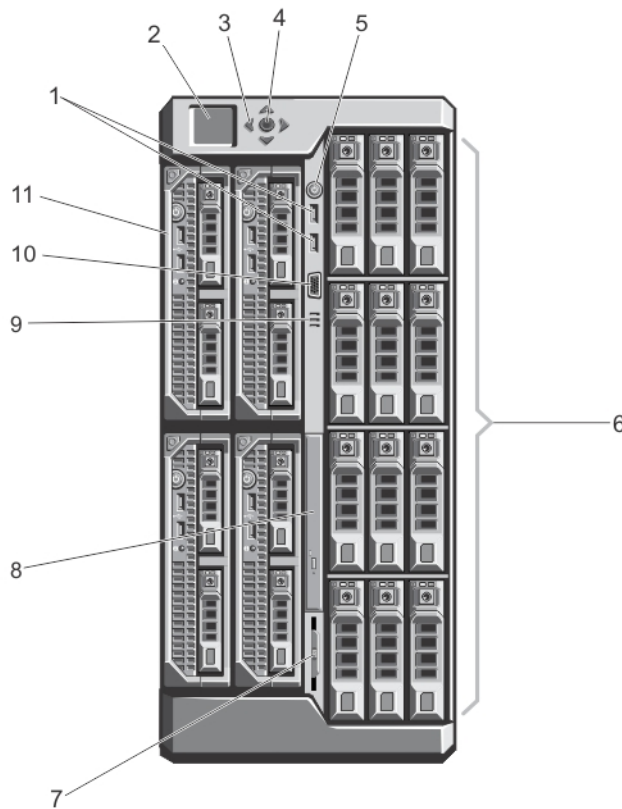




Figure 15. Front panel features and indicators — 3.5-inch hard drive chassis

Table 1. Front panel features and indicators — 2.5-inch and 3.5-inch hard drive chassis

Item	Indicator, Button, or Connector	Icon	Description
1	USB connectors (2)		Allows a keyboard and mouse to be connected to the system.
2	LCD panel		Provides system information and status and error messages to indicate when the system is operating correctly or when the system needs attention.
3	LCD menu scroll buttons (4)		Moves the cursor in one-step increments.
4	Selection ("check") button		Selects and saves an item on the LCD screen and moves to the next screen.
5	Enclosure power-on indicator, power button		The power-on indicator glows when the enclosure power is on. The power button controls the power supply unit output to the system.
6	Hard drives		<p><b>2.5-inch hard drive enclosure</b> Up to twenty five 2.5-inch hot-swappable hard drives.</p> <p><b>3.5-inch hard drive enclosure</b> Up to twelve 3.5-inch hot-swappable hard drives.</p>
7	Information tag		A slide-out label panel which allows you to record system information such as Service Tag, NIC, MAC address, the



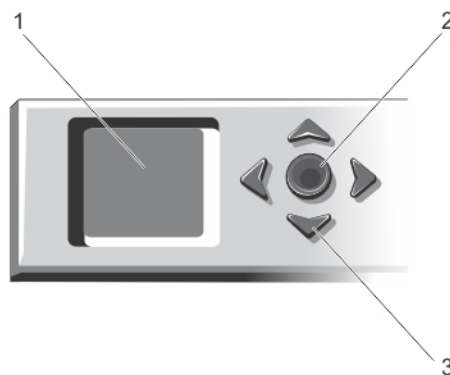
## Drive-Status Indicator Pattern Condition

**NOTE:** The drive status indicator remains off until all hard drives are initialized after the system is turned on. Drives are not ready for insertion or removal during this time.

Blinks green, amber, and off	Predicted drive failure
Blinks amber four times per second	Drive failed
Blinks green slowly	Drive rebuilding
Steady green	Drive online
Blinks green three seconds, amber three seconds, and off six seconds	Rebuild aborted

## LCD module

You can use the LCD panel on the enclosure chassis to perform configuration and diagnostics, and to obtain status information about the chassis and its contents.



**Figure 17. LCD display**

- |   |                    |   |                            |
|---|--------------------|---|----------------------------|
| 1 | LCD screen         | 2 | selection ("check") button |
| 3 | scroll buttons (4) |   |                            |

## LCD module features

The primary function of the LCD module is to provide real-time information on the health and status of the modules in the enclosure.

LCD module features include:

- A deployment setup that allows you to configure the CMC network settings during initial system setup.
- Menus to configure the iDRAC in each server module.
- Status information screens for each server module.
- Status information screens for the modules installed in the back of the enclosure, including the I/O module, blower modules, CMC, KVM, and power supply units.

- An **IP Summary** screen listing the IP addresses of all components in the system.
- Real time power consumption statistics, including high and low values, and average power consumption.
- Ambient temperature values.
- AC power information.
- Critical failure alerts and warnings.

## Using the LCD module menus

The **LCD Setup** menu displays a menu of items that can be configured.

Use the up and down arrow buttons to highlight an item in the menu or highlight the **Back** icon if you want to return to the **Main** menu.

Press the center button to activate your selection.

Key	Action
Left and right arrows	Move between screens
Up arrow or down arrow	Move to the previous or next option on a screen
Center button	Select and save an item and move to the next screen

## Main menu

From the **Main** menu, you can navigate to one of the following screens:

Screen	Description
LCD Setup	Contains the options such as <b>Language Setup</b> , <b>LCD Orientation</b> , and the <b>Default Screen</b> .
KVM Mapping	Contains the options to map or unmap the KVM to the servers.
DVD Mapping	Contains the option to map or unmap the DVD drive on the chassis to the servers.
Enclosure	Displays status information for the chassis.
IP Summary	Displays IPv4 and IPv6 information about CMC and iDRAC.

## LCD Setup menu

The **LCD Setup Menu** displays a menu of items that can be configured:

<b>Language Setup</b>	Select the language you want to use for LCD screen text and messages.
<b>LCD Orientation</b>	Select either Tower Mode or Rack Mode based on the installation orientation of the chassis.
<b>Default Screen</b>	Select the screen ( <b>Main</b> menu, <b>Front Status</b> , <b>Rear Status</b> , <b>Side Status</b> , or <b>Custom</b> ) that is displayed when there is no activity on the LCD panel.

Use the up and down arrow buttons to highlight an item in the menu or highlight the **Back** icon if you want to return to the **Main** menu.

Press the center button to activate your selection.

## DVD mapping

From this screen, you can view the DVD to server mapping information, map another server to the DVD drive on the chassis, or unmap the existing connection.

## KVM Mapping menu

From this screen, you can view the KVM to server mapping information, map another server to the KVM, or unmap the existing connection.

 **NOTE: The KVM does not map to the CMC.**

## Enclosure menu

From this screen, you can navigate to the following screens:

- Front Status
- Rear
- Side
- Enclosure status

Use the navigation buttons to highlight the desired item (highlight the **Back** icon to return to the **Main** menu) and press the center button. The selected screen is displayed.

## IP Summary menu

The **IP Summary** screen displays the IP information for CMC (IPv4 and IPv6) and iDRAC (IPv4 and IPv6) on each of the installed servers.

Use the up and down arrow buttons to scroll through the list. Use the left and right arrow buttons to scroll selected messages that are longer than the screen.

Use the up and down arrow buttons to select the **Back** icon and press the center button to return to the **Enclosure** menu.

# Back panel features and indicators

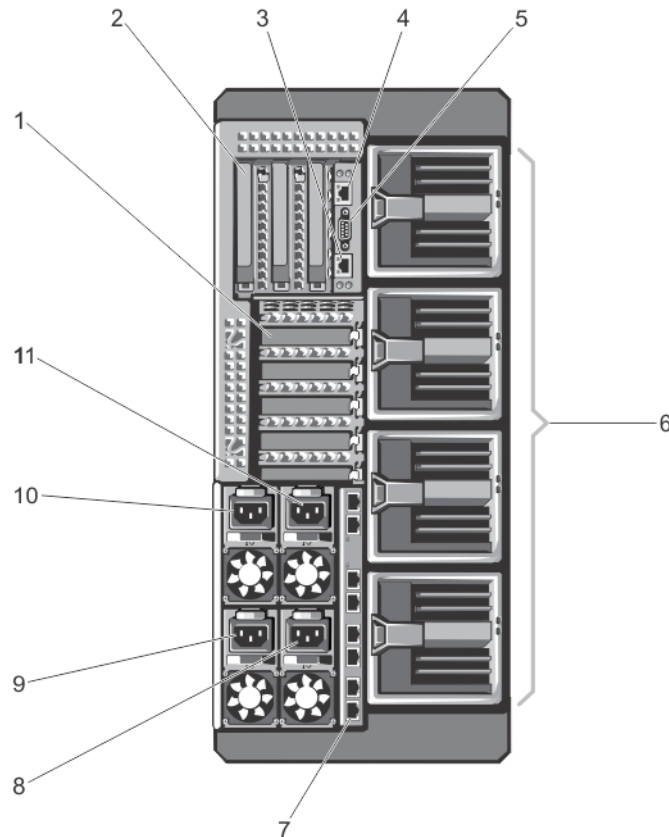





Figure 18. Back panel features and indicators

Table 2. Back panel features and indicators

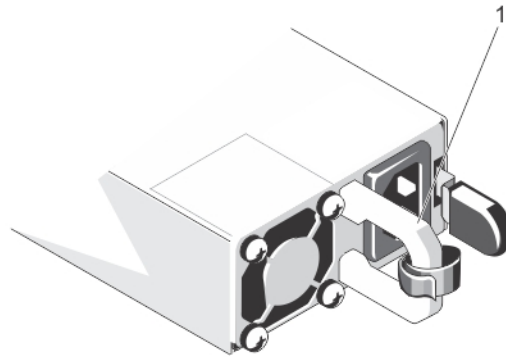
Item	Indicator, Button, or Connector	Icon	Description
1	PCIe expansion card slots low-profile (5)		Allows you to connect up to five low-profile PCI Express expansion cards.
2	PCIe expansion card slots full height (3)		Allows you to connect up to three full-height PCI Express expansion cards.
3	CMC GbE port 2		Connects the network cable from the management system to the secondary CMC.
4	CMC GbE port 1		Connects the network cable from the management system to the primary CMC.
5	Serial connector		DB-9 serial connector for CMC configuration.
6	Blower modules (4)		Provide cooling for the server modules.
7	I/O module ports		Network interface for I/O modules.
8	Power supply unit (PSU) (PSU4)		1100 W or 1600 W AC
9	PSU (PSU3)		1100 W or 1600 W AC



Item	Indicator, Button, or Connector	Icon	Description
10	PSU (PSU1)		1100 W or 1600 W AC
11	PSU (PSU2)		1100 W or 1600 W AC

## Power supply unit indicators

Each AC power supply unit (PSU) has an illuminated translucent handle that serves as an indicator to show whether power is present or whether a power fault has occurred. The AC PSUs must be connected to a Power Distribution Unit (PDU) or to an electrical outlet.



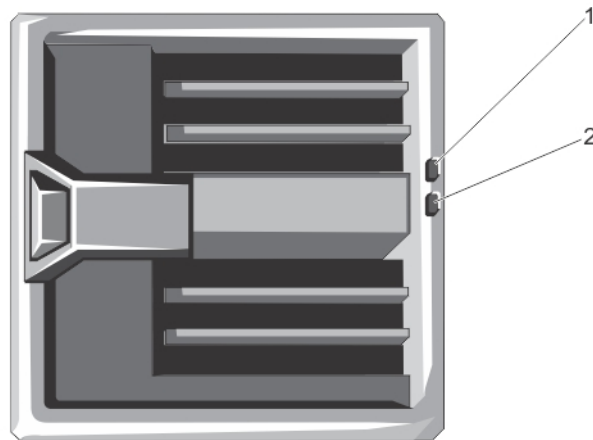
**Figure 19. Power supply indicators**

1 AC PSU status indicator/handle

The PSU indicators provide the following information:

Power Indicator Pattern	Condition
Not lit	Power is not connected.
Green	In standby mode, the handle glows green indicating that a valid power source is connected to the PSU and that the PSU is operational.
Flashing amber	Indicates a problem with the PSU.
Flashing green and turns off	When hot-adding a PSU, the PSU handle flashes green five times then turns off. This indicates a PSU mismatch. <ul style="list-style-type: none"> <li>⚠ <b>CAUTION:</b> When correcting a PSU mismatch, replace only the PSU with the flashing indicator. Swapping the opposite PSU to make a matched pair can result in an error condition and unexpected system shutdown. To switch to a new PSU rated output capacity, generation, or input voltage, you must first power down the chassis before changing the PSU configuration.</li> <li>⚠ <b>CAUTION:</b> AC PSUs support both 220 V and 110 V input voltages. When two identical PSUs receive different input voltages, they can output different wattages, and trigger a mismatch.</li> <li>⚠ <b>CAUTION:</b> All PSUs used must be of the same rated output capacity, generation, and input voltage.</li> <li>ℹ <b>NOTE:</b> The VRTX chassis supports only PSUs with a rated capacity of 1100 W or 1600 W.</li> </ul>

## Blower module indicators



**Figure 20. Blower module indicators**

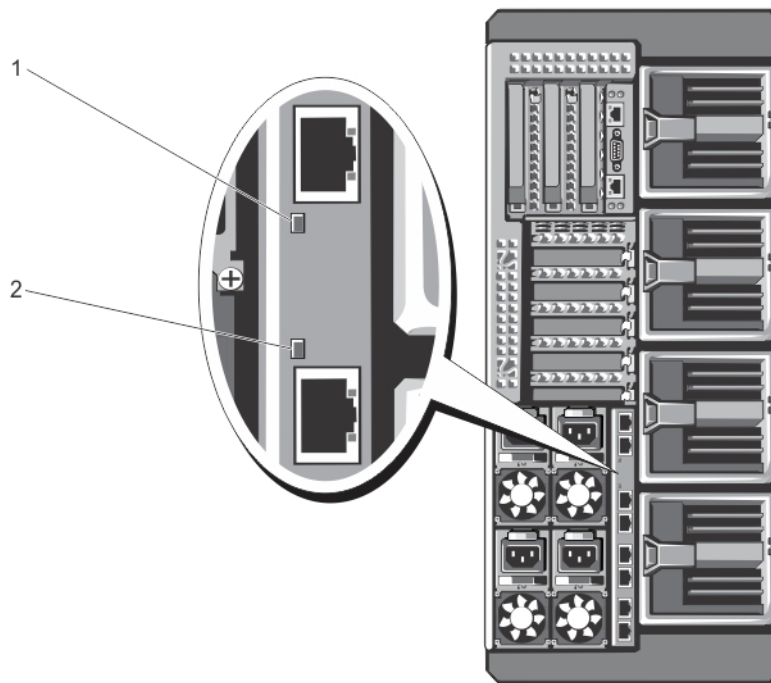
1 blower module power indicator

2 blower module fault indicator

The indicators provide the following information:

Indicator	Description	
Blower module power indicator	Steady Green	The blower module is receiving power.
	Off	The blower module is not receiving power.
Blower module fault indicator	Blinking Amber	The blower module is in a fault condition.
	Off	The blower module is operating normally.

## I/O module indicators



**Figure 21. I/O module indicators**

1 power indicator

2 status indicator

The indicators provide the following information:

Indicator	Description
Power indicator	Green The I/O module is operating normally.
	Off The I/O module is powered off.
Status indicator	Blue The I/O module is operating normally.
	Blinking Blue The CMC is identifying the I/O module.
	Blinking Amber The I/O module is in a fault condition.
	Off The I/O module is powered off, or booting is in progress.

For more information, see the I/O module documentation at [Dell.com/poweredgemanuals](http://Dell.com/poweredgemanuals).

# CMC indicators

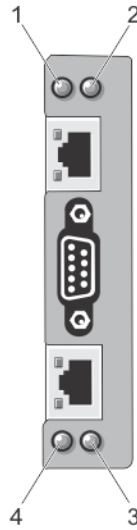


Figure 22. CMC indicators

- |   |   |   |   |
|---|---|---|---|
| 1 | status/identification indicator (CMC 1) | 2 | power indicator (CMC 1)                 |
| 3 | power indicator (CMC 2)                 | 4 | status/identification indicator (CMC 2) |

The CMC indicators on the back panel of the enclosure provide the following information:

Indicator	Description
<b>Power indicator</b>	<b>Green</b> The CMC is receiving power.
	<b>Off</b> The CMC is not receiving power.
<b>Status indicator</b>	<b>Blue</b> The CMC is active and operating normally.
	<b>Amber</b> The CMC is in fault condition.

# CMC features

The CMC provides the following multiple systems management functions:

- Enclosure-level real-time automatic power and thermal management:
  - Monitors system power requirements and supports the optional Dynamic Power Supply Engagement (DPSE) mode. The DPSE mode improves power efficiency by allowing the CMC to dynamically place power supply units in standby mode, depending on the load and redundancy requirements.
  - Reports real-time power consumption, which includes logging high and low points with a time stamp.
  - Supports setting an optional enclosure Maximum Power Limit, which either alerts or takes actions, such as throttling server modules and/or preventing the power up of new server modules to keep the enclosure under the defined maximum power limit.
  - Monitors and automatically controls cooling fans based on actual ambient and internal temperature measurements.
  - Provides comprehensive enclosure inventory and status or error reporting.

- Centralized configuration of the following:
  - The shared storage settings of the enclosure.
  - Mapping of add-in PCIe cards to the server modules.
  - The network and security settings of the enclosure.
  - Power redundancy and power ceiling settings.

**NOTE:** Modifying the modular enclosure redundancy policy is recommended to be performed while the modular enclosure is powered off.

- I/O module and iDRAC network settings.
- First boot device on the server modules.
- Checks I/O fabric consistency for the I/O module, PCIe slots, storage subsystem, and server modules and disables components if necessary to protect the system hardware.
- User access security.

## CMC fail-safe mode

The VRTX enclosure enables the fail-safe mode to protect the server modules and the I/O module from failures. The fail-safe mode is enabled when no CMC is in control of the chassis. During the CMC failover period or during a single CMC management loss:

- server modules cannot be accessed remotely
- you cannot turn on a server module(s)
- the cooling fans continue to operate at the same speed

The following are some of the conditions that can result in CMC management loss:

Condition	Description
CMC removal	Chassis management resumes after replacing CMC, or after failover to standby CMC.
CMC network cable removal or network connection loss	Chassis management resumes after the chassis fails over to the standby CMC. Network failover is only enabled in redundant CMC mode.
CMC reset	Chassis management resumes after the CMC reboots or chassis fails over to the standby CMC.
CMC failover command issued	Chassis management resumes after the chassis fails over to the standby CMC.
CMC firmware update	Chassis management resumes after the CMC reboots or chassis fails over to the standby CMC. It is recommended that you update the standby CMC first so that there is only one failover event. For more information about updating the CMC firmware, see the <i>Dell Chassis Management Controller for Dell PowerEdge VRTX User's Guide</i> at <a href="http://Dell.com/esmmanuals">Dell.com/esmmanuals</a> .
CMC error detection and correction	Chassis management resumes after the CMC resets or chassis fails over to the standby CMC.

**NOTE:** You can configure the enclosure with a single CMC or with redundant CMCs. In redundant CMC configurations, if the primary CMC loses communication with the enclosure or the management network, the standby CMC takes over chassis management.

## Configuration wizard

The CMC is preset for Dynamic Host Configuration Protocol (DHCP). To use a static IP address, you must toggle the CMC setting from DHCP to a static address by either running the LCD configuration wizard, or by using a management station and CLI commands. For more information, see the *Dell Chassis Management Controller for Dell PowerEdge VRTX User's Guide* at [Dell.com/esmmanuals](http://Dell.com/esmmanuals).

To set up a network using the LCD configuration wizard:

- 1 If the enclosure is off, press the enclosure power button to turn it on.  
The LCD screen displays a series of initialization screens as it turns on. When it is ready, the **Language Setup** screen is displayed.
- 2 Select a language from the options in the dialog box.  
The following message is displayed on the enclosure screen: `Configure Enclosure?`
- 3 Press the center button to continue to the CMC **Network Settings** screen.
- 4 Configure the CMC network settings for your network environment:
  - Network speed
  - Duplex mode
  - Network mode (DHCP or static)
  - Static IP address, subnet mask, and gateway values (if static mode was selected)
  - DNS settings
- 5 If required, configure the iDRAC network settings.  
For more information about iDRAC, see the *iDRAC User's Guide* at [Dell.com/support/manuals](http://Dell.com/support/manuals).

**NOTE:** The configuration wizard automatically configures each server module's iDRAC internal network interface if you do not choose to manually configure the iDRAC settings.

**NOTE:** You cannot set a static IP address for the iDRAC using the LCD configuration wizard. To set a static IP address, use the CMC web-based interface or Remote Access Controller Administrator (RACADM).

- 6 Review the settings on the **Network Summary** screen:
  - If the settings are correct, press the center button to close the configuration wizard and return to the **Main Menu**.
  - If the settings are not correct, use the left arrow key to return to the screen for that setting and correct it.

After you complete the configuration wizard, the CMC is available on your network.

## System messages

System messages related to the server modules in the enclosure may appear on the monitor screen to notify you of a possible problem with a server module. For a detailed listing of these error messages, including possible causes and solutions, see the server module documentation.

## LCD messages

For a complete list of messages that are displayed on the front panel LCD screen, see the *Dell PowerEdge VRTX Chassis Management Controller Firmware Event Message Reference Guide* at [Dell.com/esmmanuals](http://Dell.com/esmmanuals).

## Documentation matrix

The documentation matrix provides information on documents that you can refer to, for setting up and managing your system.

**Table 3. Documentation matrix**

To...	Refer to...
Install your system into a rack	Rack documentation included with your rack solution
Set up your system and know the system technical specifications	Getting Started Guide
Set up and configure your system	Quick Start Reference Guide
Install the operating system	Operating system documentation at <a href="http://Dell.com/operatingsystemmanuals">Dell.com/operatingsystemmanuals</a>

To...	Refer to...
Get an overview of the Dell Systems Management offerings	Dell OpenManage Systems Management Overview Guide at <a href="https://www.dell.com/openmanagemanuals">Dell.com/openmanagemanuals</a> > <b>OpenManage software</b>
Install, configure, and use the Chassis Management Controller (CMC)	CMC User's Guide at <a href="https://www.dell.com/esmmanuals">Dell.com/esmmanuals</a>
Configure and log in to iDRAC, set up managed and management system, know the iDRAC features and troubleshoot using iDRAC	Integrated Dell Remote Access Controller User's Guide at <a href="https://www.dell.com/idracmanuals">Dell.com/idracmanuals</a>
Know about the RACADM subcommands and supported RACADM interfaces	RACADM Command Line Reference Guide for iDRAC and CMC at <a href="https://www.dell.com/idracmanuals">Dell.com/idracmanuals</a>
Launch, enable and disable Lifecycle Controller, know the features, use and troubleshoot Lifecycle Controller	Dell Lifecycle Controller User's Guide at <a href="https://www.dell.com/idracmanuals">Dell.com/idracmanuals</a>
Use Lifecycle Controller Remote Services	Dell Lifecycle Controller Remote Services Quick Start Guide at <a href="https://www.dell.com/idracmanuals">Dell.com/idracmanuals</a>
Set up, use, and troubleshoot OpenManage Server Administrator	Dell OpenManage Server Administrator User's Guide at <a href="https://www.dell.com/openmanagemanuals">Dell.com/openmanagemanuals</a> > <b>OpenManage Server Administrator</b>
Install, use and troubleshoot OpenManage Essentials	Dell OpenManage Essentials User's Guide at <a href="https://www.dell.com/openmanagemanuals">Dell.com/openmanagemanuals</a> > <b>OpenManage Essentials</b>
Know the system features, remove and install system components, and troubleshoot components	Owner's Manual at <a href="https://www.dell.com/poweredgemanuals">Dell.com/poweredgemanuals</a>
Know the server module features, remove and install server module components, troubleshoot server module components	Server module Owner's Manual at <a href="https://www.dell.com/poweredgemanuals">Dell.com/poweredgemanuals</a>
Know about I/O module features, configure the I/O module and additional I/O module information	I/O module documentation at <a href="https://www.dell.com/poweredgemanuals">Dell.com/poweredgemanuals</a>
Know the features of the storage controller cards, deploy the cards, and manage the storage subsystem	Storage controller documentation at <a href="https://www.dell.com/storagecontrollermanuals">Dell.com/storagecontrollermanuals</a>
See the event and error messages generated by the system firmware and agents that monitor system components	Dell Event and Error Messages Reference Guide at <a href="https://www.dell.com/openmanagemanuals">Dell.com/openmanagemanuals</a> > <b>OpenManage software</b>

## Quick Resource Locator

Use the Quick Resource Locator (QRL) to get immediate access to system information and how-to videos. This can be done by visiting [Dell.com/QRL](https://www.dell.com/QRL) or by scanning a model specific QR code located on your Dell PowerEdge system using your smartphone. You can also



access your system information and how-to videos by scanning the following QR code.

# Initial system configuration

## Before you begin

**CAUTION:** The enclosure power supply units (PSUs) must be connected to a PDU or to an electrical outlet. The PSUs require a 100 V to 120 V or 200 V to 240 V power source. You can select only one AC power input, as the system does not operate at both ranges simultaneously.

**NOTE:** Ensure that all the component software are upgraded to the latest versions. For information on the latest supported firmware and driver versions, see the Drivers & Downloads link on [Dell.com/support/drivers](http://Dell.com/support/drivers), for your system.

- Your system supports server modules that are specifically configured for the enclosure, and can be identified by a label marked PCIe on the server module. If you install server modules that are not configured for the enclosure, an error message is displayed. For more information on configuring a server module for the enclosure, see [Configuring A Server Module](#).
- Ensure that you have downloaded the latest BIOS on the server module(s) from [Dell.com/support](http://Dell.com/support).
- Update all PCIe mezzanine card firmware and iDRAC firmware on the server module(s).
- Download the latest version of CMC firmware from [Dell.com/support](http://Dell.com/support). Also, make sure that you have the *Dell Systems Management Tools and Documentation DVD* that was included with your system.
- If your network uses static addressing, you need the IP address, subnet mask, and gateway to configure the CMC and other modules in the enclosure.

## Initial setup sequence

**CAUTION:** To maintain optimum thermal conditions, ensure that there are no obstructions to airflow on the front and back of the enclosure. The front and back of the enclosure must have at least 30 cm (12-inches) and 61 cm (24 inches) of unobstructed space respectively.

- Unpack the enclosure and the server module(s) and identify each item. For more information, see the *Getting Started Guide* and *Rack Installation Guide* at [Dell.com/poweredge/manuals](http://Dell.com/poweredge/manuals).
- The tower system has four feet on its bottom panel that can be extended outward to help properly stabilize the system. You can also install the optional wheel assembly. For more information, see [Installing The Wheel Assembly](#).

**WARNING:** Failure to extend the system feet outward poses the risk of having the system tip over, possibly causing bodily injury or damage to the system.

**CAUTION:** Rolling the system on its wheels can cause vibrations that can damage the system.

- If you are using the optional rack configuration, assemble the rails and install the system in the rack following the safety instructions and the rack installation instructions provided with your system. For more information about converting the system to rack mode, see [Converting The System From Tower Mode To Rack Mode](#).

- 1 Install the server module(s).

**CAUTION:** Do not turn on the server module(s) until you have configured the I/O module.

- 2 Connect the network cable to the I/O module to provide network connection to the server.

**NOTE:** If you have a pass-through module installed in the enclosure, each server module requires its own network cable.

- 3 Connect the power supply units to a PDU or electrical outlet using the power cables.

- 4 Optionally, connect the keyboard, video, and mouse to the enclosure.

- 5 Press the power button on the enclosure's front panel.

Alternatively, you can also turn on the chassis from the CMC Web interface after completing step 7.



- Using the LCD panel on the front of the system, provide CMC with a static IP address or configure it for DHCP.  
The LCD configuration wizard allows you to quickly configure the CMC and iDRAC management interfaces and manage the enclosure remotely. You can also use a management station and the RACADM CLI to configure the CMC.

**NOTE:** For a detailed description on configuring the CMC settings, see the *Dell Chassis Management Controller for Dell PowerEdge VRTX User's Guide* at [Dell.com/esmmanuals](http://Dell.com/esmmanuals).

- Connect to the CMC IP address through the Web browser using the default logon credentials.  
The default user name is `root` and password is `calvin`.
- Provide each iDRAC with an IP address in the CMC Web interface and enable the LAN and IPMI interface.

**NOTE:** iDRAC LAN interface on some server modules are disabled by default.

- Provide the switch module with an IP address in the CMC Web interface.

**NOTE:** No configuration is required if you are installing a pass-through module.

- Connect to each iDRAC through the Web browser and provide final configuration of iDRAC.  
The default user name is `root` and password is `calvin`.
- Connect to the switch module through the Web browser and provide final configuration of the switch module.

**NOTE:** No configuration is required if you are installing a pass-through module.

- Turn on the server modules and install the operating system.

## Logging in to the CMC

You can perform the initial network configuration of CMC before or after CMC has an IP address.

You can log in to CMC as a CMC local user, as a Microsoft Active Directory user, or as an LDAP user. You can also log in using Single Sign-On or Smart Card.

For more information about managing the chassis and configuring the settings, see the *Dell Chassis Management Controller for Dell PowerEdge VRTX User's Guide* at [Dell.com/esmmanuals](http://Dell.com/esmmanuals).

# Configuring enclosure components

## Fabric A

Fabric A refers to the Ethernet connectivity provided to the server modules by the I/O module installed at the back of the PowerEdge VRTX enclosure.

Fabric A provides internal connection to four lanes per server module for a maximum of 16 lanes. The number of external connections are based on the I/O module installed. The R1-2401 switch and R1-PT pass-through module provide a maximum of eight RJ-45 1 GbE ports. The R1-2210 switch module provides a maximum of two RJ-45 1 GbE ports and four SFP+ 10 GbE ports.

The following conditions apply:

- Dell PowerEdge M520 server module disables ports 3 and 4 when a pass-through module is installed. However, if you install a switch module, all four network ports on Fabric A are utilized.
- Fabric A in PowerEdge M620 is a 10 GbE capable interface. Fabric A operates at 1 GbE to support a pass-through or the R1-2401 switch module, and at 10 GbE to support the R1-2210 switch module.
- Fabric A in PowerEdge M820 is a 10 GbE capable interface. Fabric A operates at 1 GbE to support a pass-through or the R1-2401 switch module, and at 10 GbE to support the R1-2210 switch module.

For information on the supported I/O modules, see [Supported I/O Modules](#).

## Fabrics B and C

Fabrics B and C refer to the PCIe connections between the server modules and the VRTX enclosure. These fabrics support PCIe mezzanine cards installed in the server modules. The enclosure has two PCIe switches (Fabric B and Fabric C switches) integrated on the system board to connect the server modules to the Shared PowerEdge RAID Controller (PERC) card slots and eight PCIe expansion card slots on the enclosure.

**NOTE:** To locate the Shared PERC card slots and the PCIe slots on the enclosure system board, see [System Board Connectors](#).

The PCIe switch mapping to the PCIe card slots is dependent on the firmware and the software license installed on the system. For more information about mapping PCIe slots, see [Mapping PCIe Expansion Slots](#).

**NOTE:** PCIe NICs systems management is not supported on Fabrics B and C.

## I/O module and PCIe mezzanine card configuration guidelines

- Fabric A supports an Ethernet switch or a pass-through module.
- To enable switch configuration before imaging the server modules, the I/O module must be allowed to power-up before the server modules are turned on.
- Each half-height server module installed in the PowerEdge VRTX enclosure supports two PCIe mezzanine cards in Fabric B and Fabric C slots. Each full-height server module supports four PCIe mezzanine cards in the two Fabric B and two Fabric C slots. To locate the Fabric B and Fabric C slots, see the server module Owner's Manual at [Dell.com/poweredgemanuals](http://Dell.com/poweredgemanuals). The PCIe mezzanine cards are mapped to the PCIe expansion slots on the enclosure. For more information, see [Mapping PCIe Expansion Slots](#).

**NOTE:** Only PCIe mezzanine cards can be installed in Fabrics B and C of the server modules. Non-PCIe mezzanine cards such as Ethernet, Fibre Channel, or InfiniBand mezzanine cards are not supported. If you install non-PCIe mezzanine cards on the server modules, an error message is displayed on the LCD screen of the enclosure.

**NOTE:** Single PCIe mezzanine card operation is not supported.

## Supported I/O modules

The enclosure supports a switch or a pass-through module. The maximum Ethernet pass-through for a pass-through module is eight lanes. A 1 Gb switch module can accept up to 16 lanes from Fabric A and output up to eight lanes to the external ports. A 10 Gb switch module can accept up to 16 lanes from Fabric A and output six lanes to external ports (four 10 GbE SFP+ ports and two 1 GbE RJ-45 ports).

The enclosure supports the following I/O modules:

- Dell PowerEdge VRTX 1 Gb R1-PT pass-through module
- Dell PowerEdge VRTX 1 Gb R1-2401 switch module
- Dell PowerEdge VRTX 10 Gb R1-2210 switch module

**NOTE:** For more information about the I/O modules, see the I/O module documentation at [Dell.com/poweredgemanuals](https://Dell.com/poweredgemanuals).

## Configuring network settings for the I/O module

You can specify the network settings for the interface used to manage the I/O module.

Before configuring the network settings for the I/O module, make sure the I/O module is turned on.

To configure the network setting, you must have Administrator privileges for Fabric A to configure the I/O module in Group A.

You can configure the network settings using the following:

- CMC web interface
- RACADM

For more information about configuring the network settings, see the *Dell Chassis Management Controller for Dell PowerEdge VRTX User's Guide* at [Dell.com/esmanuals](https://Dell.com/esmanuals).

## Mapping PCIe expansion slots

The enclosure has two PCIe switches integrated on the system board which map the Shared PERC storage slots and PCIe expansion slots to the PCIe mezzanine cards on the server modules.

**NOTE:** Before mapping or unmapping a PCIe device, the server module must be turned off.

**NOTE:** The PCIe switch mapping is controlled by the firmware and depends on the software license installed on the system:

- With base licensing, each server module can be mapped to a maximum of two PCIe slots.
- With the advanced licensing, a server module can map all available PCIe slots.
- Default factory configuration has all PCIe slots unmapped.

**For more information about PCIe slot configuration licensing, see the *Dell Chassis Management Controller for Dell PowerEdge VRTX User's Guide* at [Dell.com/esmanuals](https://Dell.com/esmanuals).**

The switches map the mezzanine cards to the PCIe slots on the enclosure's system board. There are five PCIe low profile slots on the system board and three full-height, full-length PCIe slots on the PCIe riser. All the PCIe slots can be mapped to the PCIe mezzanine cards on the server modules to provide I/O expansion for the system:

PCIe mezzanine Fabric B and Fabric C cards on each server module are mapped to the PCIe switches which further map to the PCIe slots and the Shared PERC slots on the enclosure's system board.

**NOTE:** For information on the specifications of the supported PCIe cards, see [Expansion bus specifications](#).

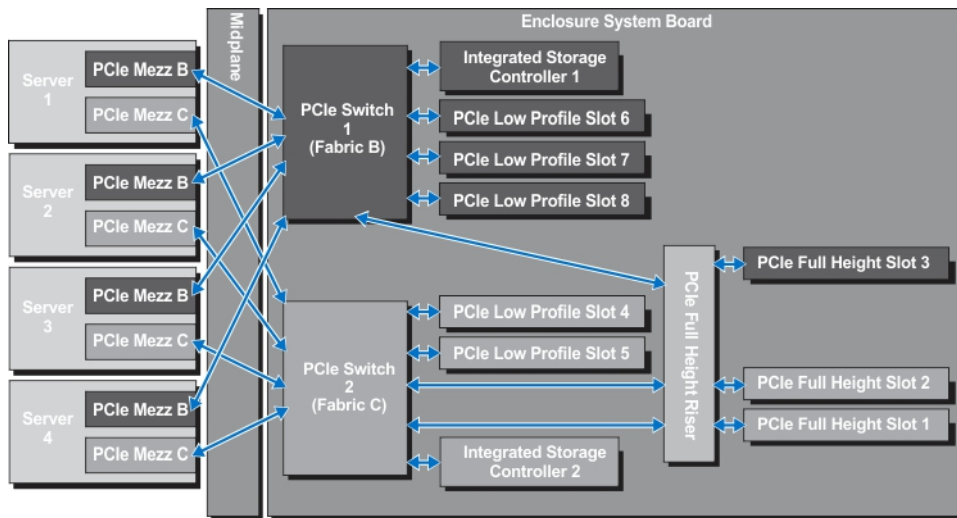


Figure 23. Mapping PCIe expansion slots — half-height server modules

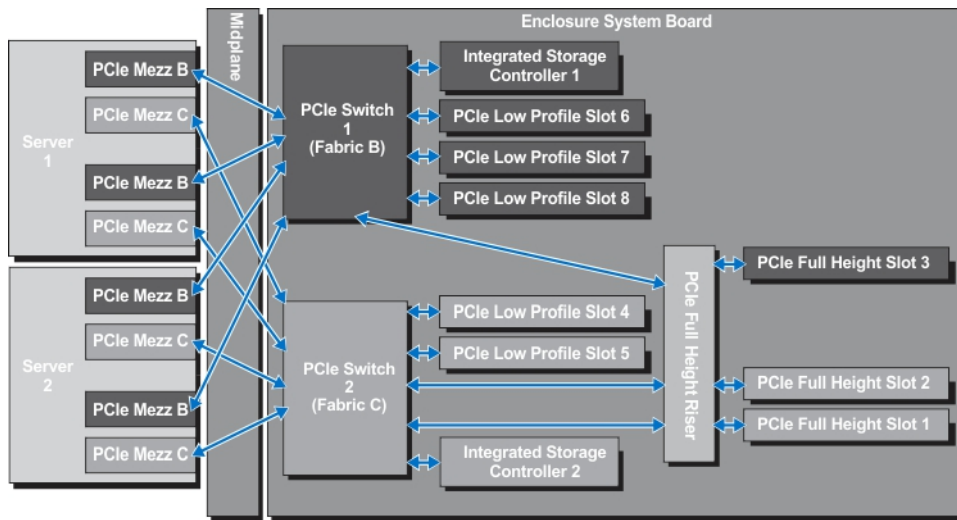


Figure 24. Mapping PCIe expansion slots — full-height server modules

## Managing PCIe slots

You can do the following using the CMC web interface:

- View the status of both individual and all PCIe slots in the chassis.
- Assign PCIe slots to server modules.

For more information about managing the PCIe slots using the CMC web interface, see the *Dell Chassis Management Controller for Dell PowerEdge VRTX User's Guide* at [Dell.com/esmanuals](http://Dell.com/esmanuals).

## Managing chassis storage

The enclosure provides shared storage with single or dual Shared PERC internal and external configurations. The Shared PERC cards support Single Root Input Output Virtualization (SR-IOV) feature and enable the server modules to map to the local storage through the PCIe switches on the enclosure system board. A server module can be mapped to either a single Virtual Disk (VD) or multiple VDs that are located on the shared storage.

For more information about the Shared PERC cards, see the *Dell Shared PowerEdge RAID Controller 8 User's Guide* at [Dell.com/poweredgemanuals](https://www.dell.com/poweredgemanuals).

You can perform the following tasks related to the enclosure storage:

- View the status of physical disks and storage controllers
- View the properties of controllers, physical disks, virtual disks, and enclosures
- Set up controllers, physical disks, and virtual disks
- Assign virtual adapters
- Troubleshoot controller, physical disks, and virtual disks
- Update storage components

**NOTE:** For information on setting up storage controllers, physical disks, and virtual disks, see the *Dell Chassis Management Controller for PowerEdge VRTX User's Guide* at [Dell.com/esmmanuals](https://www.dell.com/esmmanuals).

# Installing enclosure components

- ⚠ WARNING:** Whenever you need to lift the system, get others to assist you. To avoid injury, do not attempt to lift the system by yourself.
- ⚠ WARNING:** Exercise care when removing or installing components when the system is on, to avoid the risk of electric shock.
- ⚠ CAUTION:** To maintain optimum thermal conditions, ensure that there are no obstructions to airflow on the front and back of the enclosure. The front and back of the enclosure must have at least 30 cm (12-inches) and 61 cm (24 inches) of unobstructed space respectively.
- ⓘ NOTE:** To ensure proper operation and cooling, all bays in the enclosure must be populated at all times with either a module or with a blank.
- ⓘ NOTE:** It is recommended that you remove the front bezel, server modules, hard drives, and power supply units from the chassis to reduce weight, before laying the enclosure on its side.

## Topics:

- [Recommended tools](#)
- [Front bezel \(optional\)](#)
- [System feet—tower mode](#)
- [Wheel assembly \(optional\)—tower mode](#)
- [System cover](#)
- [Inside the system](#)
- [Hard drives](#)
- [Server modules](#)
- [Server module partitions](#)
- [Power supply units](#)
- [Cooling shroud](#)
- [Cooling fans](#)
- [Cooling fan assembly](#)
- [Blower modules](#)
- [I/O module](#)
- [Optical drive \(optional\)](#)
- [CMC cards](#)
- [PCIe cage](#)
- [Expansion cards](#)
- [Double-wide GPGPU card \(optional\)](#)
- [Integrated storage controller cards](#)
- [Shared PERC 8 External card](#)
- [System battery](#)
- [System top and base covers](#)
- [Mounting ears](#)
- [Control panel assembly](#)

- Backplane expander boards
- Hard drive backplane
- Power distribution board
- System board
- Power pass-through board
- Midplane

## Recommended tools

You may need the following items to perform the procedures in this section:

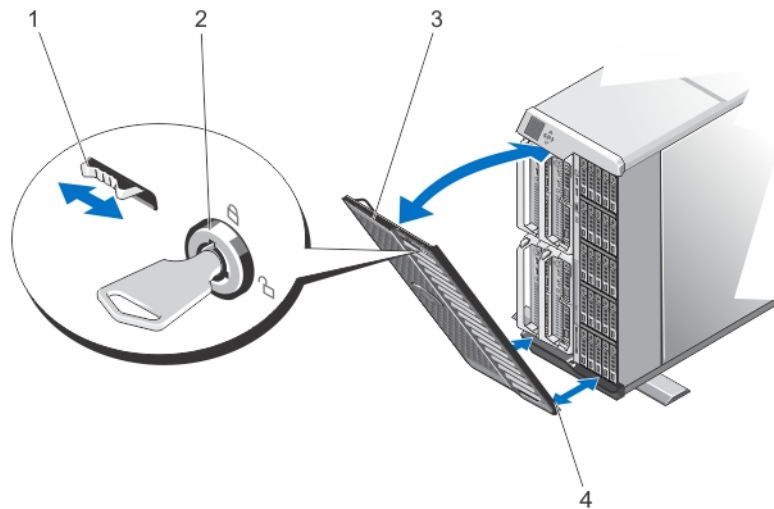
- #1 and #2 Phillips screwdrivers
- T6, T8, T10, T15, and T20 Torx drivers
- Wrist grounding strap

## Front bezel (optional)

### Installing the optional front bezel

- 1 Insert the bezel tabs into the bezel tab slots in the chassis.
- 2 Press the top end of the bezel into the chassis until the bezel locks into place.
- 3 Insert the bezel key in the keylock.
- 4 Keeping the keylock pressed with the bezel key, rotate the keylock to the locked position.

**NOTE:** The bezel key can be found taped to the inside of the bezel.



**Figure 25. Removing and installing the front bezel**

- |   |             |   |            |
|---|-------------|---|------------|
| 1 | release tab | 2 | keylock    |
| 3 | front bezel | 4 | bezel tabs |

## Removing the optional front bezel

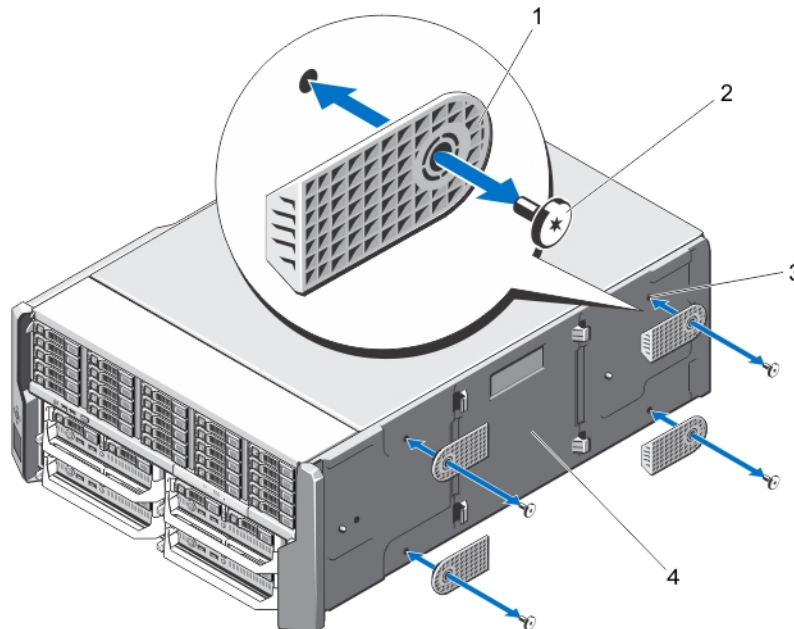
- 1 Insert the bezel key in the keylock.
- 2 Keeping the keylock pressed with the bezel key, rotate the keylock to the unlocked position.
- 3 Press the release tab at the top of the bezel toward the right.
- 4 Move the top end of the bezel away from the system.
- 5 Unhook the bezel tabs from the slots on the front of the chassis.

## System feet—tower mode

The system feet provide stability to the system in the tower mode.

## Removing the system feet

- 1 To reduce the chassis weight, remove the following (if required):
  - a Front bezel (if installed)
  - b Hard drives. See [Removing A Hot-Swap Hard Drive](#).
  - c Server modules. See [Removing A Server Module](#).
  - d Power supply units. See [Removing A Power Supply](#).
- 2 Rotate the system feet inward.
- 3 Lay the enclosure on its side on a flat, stable surface with the cover release latch side on top.
- 4 Remove the screws securing the system feet to the system base cover.



**Figure 26. Removing and installing the system feet**

- |   |                 |   |                   |
|---|-----------------|---|-------------------|
| 1 | system feet (4) | 2 | screws (4)        |
| 3 | screw holes (4) | 4 | system base cover |



## Installing the system feet

- 1 Align the screw holes on the system feet with the screw holes on the system base cover.
- 2 Install the screws to secure the system feet to the system base cover.
- 3 Place the enclosure upright on a flat, stable surface and rotate the system feet outward.
- 4 If removed, reinstall the hard drives, server modules, power supply units, and front bezel.

## Wheel assembly (optional)—tower mode

The wheel assembly provides mobility to the system in the tower mode.

The wheel assembly consists of the following:

- Wheel assembly units (front and back)
- Power cable retention bracket

## Installing the optional wheel assembly

**⚠ WARNING:** Whenever you need to lift the system, get others to assist you. To avoid injury, do not attempt to lift the system by yourself.

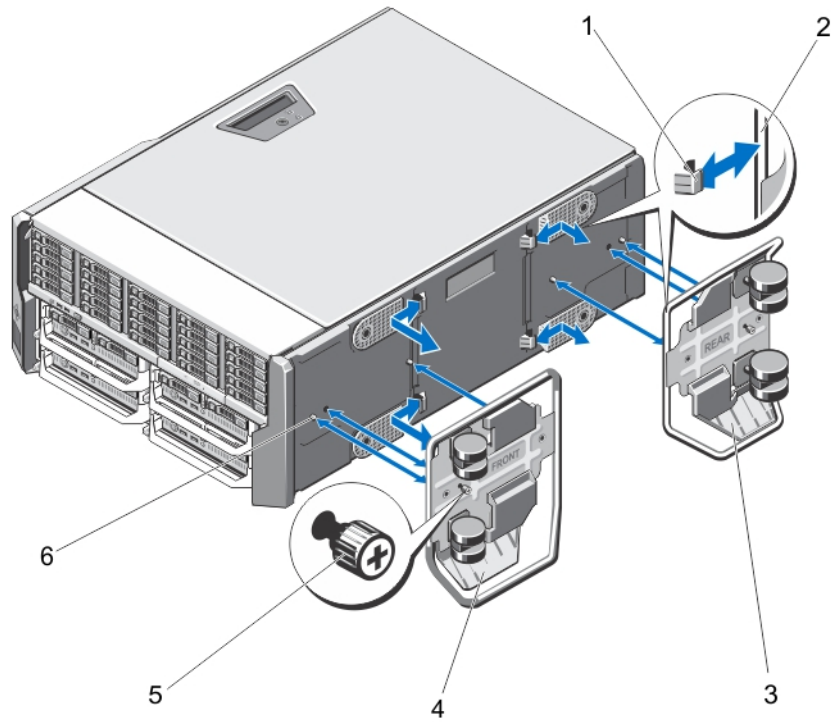
**⚠ CAUTION:** Rolling the system on its wheels can cause vibrations that can damage the system.

**ℹ NOTE:** The front and back wheel plates are labeled.

- 1 To reduce the chassis weight, remove the following (if required):
  - a Front bezel (if installed)
  - b Hard drives. See [Removing A Hot-Swap Hard Drive](#).
  - c Server modules. See [Removing A Server Module](#).
  - d Power supply units (PSUs). See [Removing A Power Supply](#).
- 2 Rotate the system feet inward and lay the enclosure on its side on a sturdy, stable surface with the cover release latch side on top, and the base of the enclosure extending slightly off the surface edge.
- 3 Tilting the front wheel plate toward the hooks on the system base cover, align the metal stand on the wheel plate with the hooks.
- 4 Insert the metal stand on the front wheel plate into the hooks until firmly seated.
- 5 Lower the other end of the front wheel plate to the chassis base and align the slot on the wheel plate with the tab on the system base cover.
- 6 Tighten the screw on the front wheel plate to secure it to the system base cover.
- 7 Tilting the back wheel plate toward the hooks on the system base cover, align the metal stand on the wheel plate with the hooks.
- 8 Insert the metal stand on the back wheel plate into the hooks until firmly seated.
- 9 Lower the other end of the back wheel plate to the chassis base and align the slot on the wheel plate with the tab on the system base cover.
- 10 Tighten the screw on the back wheel plate to secure it to the system base cover.
- 11 Place the enclosure upright on a sturdy, stable surface.
- 12 If removed, reinstall the hard drives, server modules, PSUs, and front bezel.
- 13 Align the tabs on the power cable retention bracket with the slots on the back end of the chassis base, below the PSU bay.

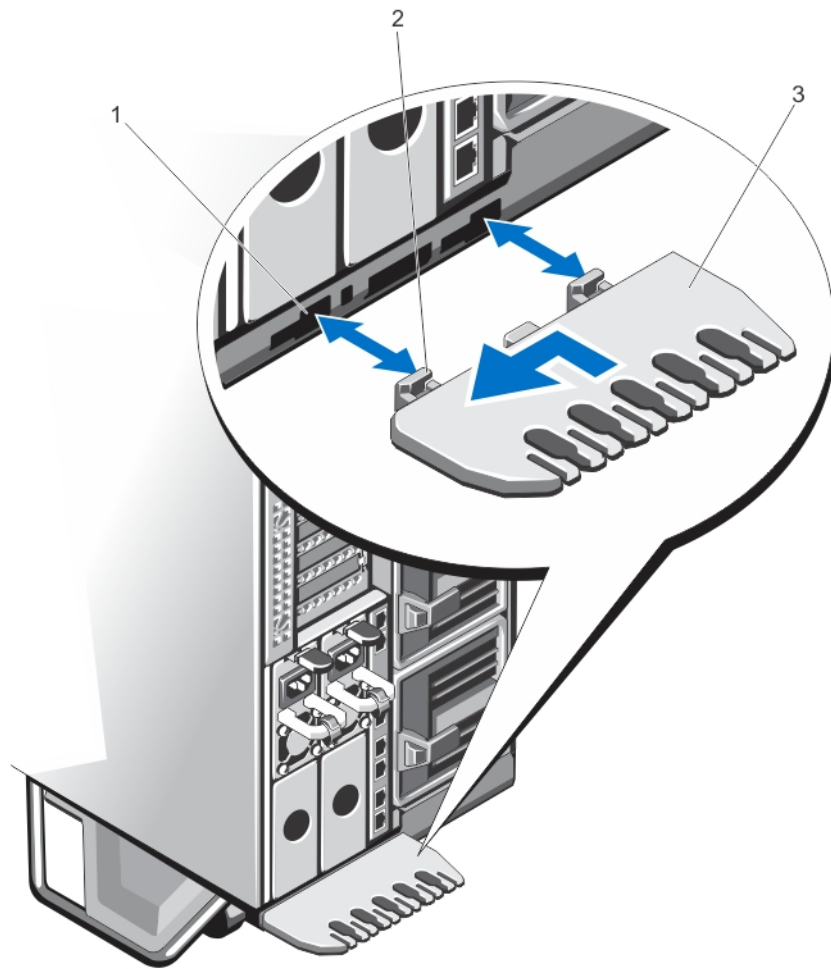
**ℹ NOTE:** Place the enclosure in the upright position before installing the power cable retention bracket.

- 14 Insert the power cable retention bracket into the slots and slide the bracket to the left to lock it.
- 15 Route the PSU cables through the power cable retention bracket.



**Figure 27. Removing and installing the wheel assembly**

- |   |                                |   |                               |
|---|--------------------------------|---|-------------------------------|
| 1 | hooks for the metal stands (4) | 2 | metal stands (2)              |
| 3 | back wheel plate               | 4 | front wheel plate             |
| 5 | screws (2)                     | 6 | tabs on system base cover (4) |



**Figure 28. Removing and installing the power cable retention bracket**

- |  |   |
|--|---|
| <ul style="list-style-type: none"> <li>1 chassis slots</li> <li>3 power cable retention bracket</li> </ul> | <ul style="list-style-type: none"> <li>2 tabs on the power cable retention bracket (2)</li> </ul> |
|--|---|

## Removing the optional wheel assembly

- 1 Remove any cables routed through the power cable retention bracket.
- 2 Slide the power cable retention bracket to the right to unlock it.
- 3 Holding it by the edges, pull the bracket out of the chassis slots and away from the chassis.
- 4 To reduce the chassis weight, remove the following (if required):
  - a Front bezel (if installed)
  - b Hard drives. See [Removing A Hot-Swap Hard Drive](#).
  - c Server modules. See [Removing A Server Module](#).
  - d Power supply units (PSUs). See [Removing A Power Supply](#).
- 5 Lay the enclosure on a sturdy, stable surface with the cover release latch side on top, and the base of the enclosure extending slightly off the surface edge.
- 6 Loosen the two screws securing the front and back wheel plates to the chassis.
- 7 Remove the metal stands on the front and back wheel plates from the hooks on the system base cover.
- 8 Remove the front and back wheel plates away from the chassis base.

- 9 Place the enclosure upright on a sturdy, stable surface and rotate the system feet outward.

## System cover

### Opening the system

**⚠ CAUTION:** Installing the feet on a standalone tower system is necessary to provide a stable foundation for the system. Failure to install the feet poses the risk of having the system tip over, possibly causing damage to the system or bodily injury.

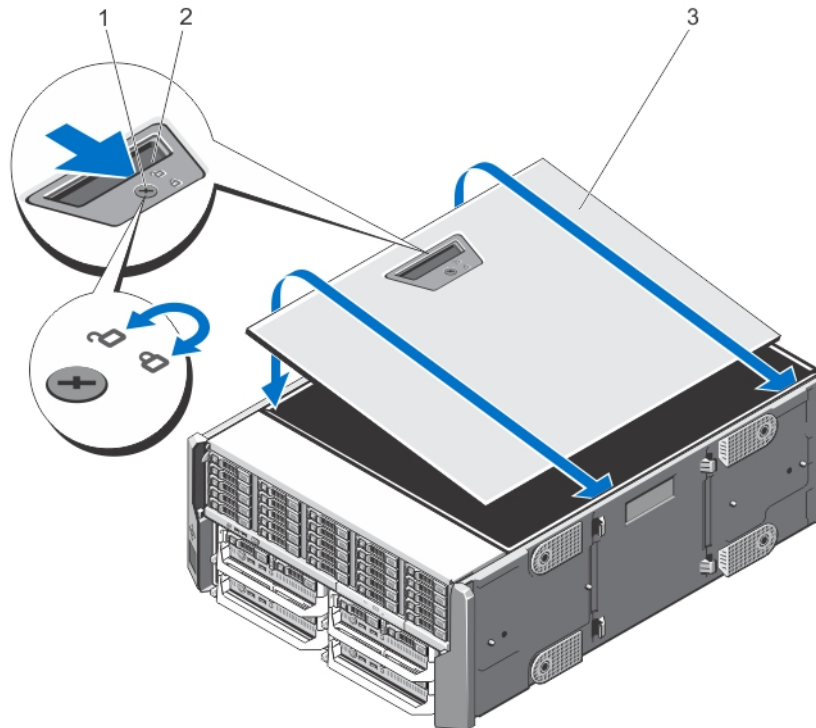
**ⓘ NOTE:** It is recommended that you always use an antistatic mat and antistatic strap while working on components inside the system.

**ⓘ NOTE:** To replace hot-swappable components inside the enclosure, you do not need to turn off the enclosure or lay it on its side, when opening the system.

- 1 If installed, remove the front bezel.
- 2 Turn off the server modules using the operating system commands or the CMC.
- 3 Turn off the enclosure and attached peripherals, and disconnect the enclosure from the electrical outlet.
- 4 To reduce the chassis weight, remove the following (if required):
  - a Hard drives. See [Removing A Hot-Swap Hard Drive](#).
  - b Server modules. See [Removing A Server Module](#).
  - c Power supply units (PSUs). See [Removing A Power Supply](#).
- 5 If applicable, rotate the system feet inward and lay the system on its side on a flat stable surface, with the cover release latch side on top.

**ⓘ NOTE:** For systems with the wheel assembly installed, ensure that you lay the system on a sturdy surface with the wheel assembly extending off the edge of the surface.

- 6 Rotate the latch release lock counter clockwise to the unlocked position.
- 7 Press the cover release latch and lift the cover away from the system.



**Figure 29. Opening and closing the system**

- |   |                    |   |                     |
|---|--------------------|---|---------------------|
| 1 | latch release lock | 2 | cover release latch |
| 3 | system side cover  |   |                     |

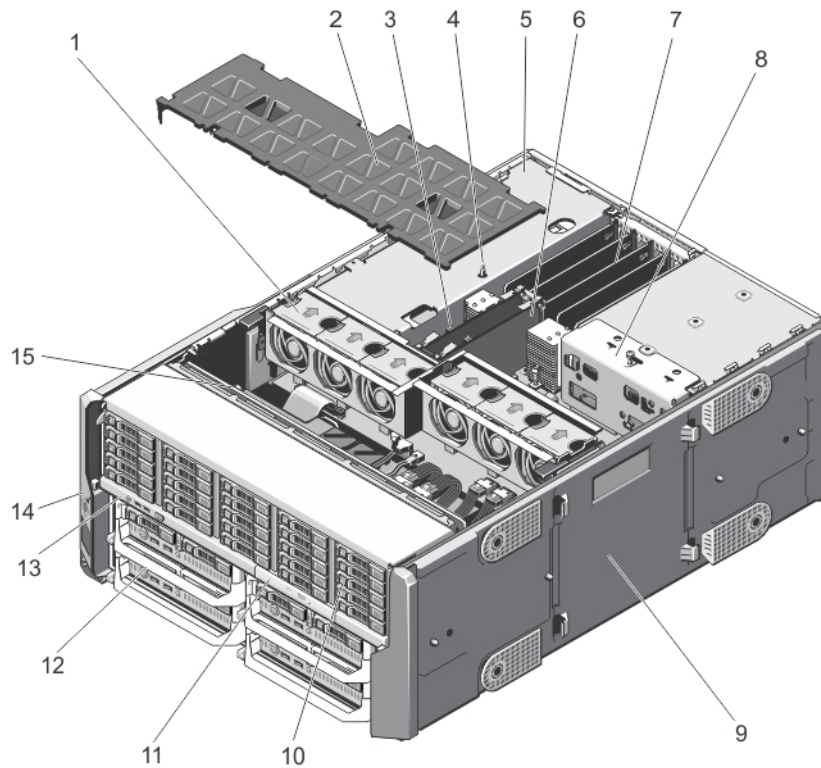
## Closing the system

- 1 Place the bottom edge of the cover, opposite from the cover release latch, into the slots in the system chassis.
- 2 Lower the cover into the chassis.
- 3 Press the latch end of the cover into the chassis until the latch locks into place.
- 4 Turn the cover latch release lock clockwise to the locked position.
- 5 If applicable, place the system upright on a flat, stable surface and rotate the system feet outward.
- 6 If removed, reinstall the hard drives, server modules, and power supply units.
- 7 Reconnect the enclosure to its electrical outlet and turn the enclosure on, including any attached peripherals.
- 8 Turn on the server modules using the operating system commands or the CMC.
- 9 If applicable, install the front bezel.

## Inside the system

**⚠ CAUTION:** Many repairs may only be done by a certified service technician. You should only perform troubleshooting and simple repairs as authorized in your product documentation, or as directed by the online or telephone service and support team. Damage due to servicing that is not authorized by Dell is not covered by your warranty. Read and follow the safety instructions that are shipped with your product.

**📌 NOTE:** Components that are hot-swappable are marked orange and touch points on the components are marked blue.



**Figure 30. Inside the system**

- |    |   |    |                                  |
|----|---|----|----------------------------------|
| 1  | cooling fans (6)                        | 2  | cooling shroud                   |
| 3  | CMC card indicators (2)                 | 4  | chassis intrusion switch         |
| 5  | PCIe cage                               | 6  | CMC cards (2)                    |
| 7  | low profile expansion card divider unit | 8  | power distribution board bracket |
| 9  | system base cover                       | 10 | hard drives (25)                 |
| 11 | optical drive                           | 12 | server modules                   |
| 13 | control panel                           | 14 | mounting ears (2)                |
| 15 | hard drive backplane                    |    |                                  |

## Hard drives

- The 3.5-inch hard drive enclosure supports up to twelve hot-swappable 3.5-inch hard drives.
- The 2.5-inch hard drive enclosure supports up to twenty-five hot-swappable 2.5-inch hard drives.
- All hard drives connect to the system board through the hard drive backplane.
- Hard drives are supplied in hot-swappable hard drive carriers that fit in the hard drive slots.
- Use only hard drives that have been tested and approved for use with the hard drive backplane.

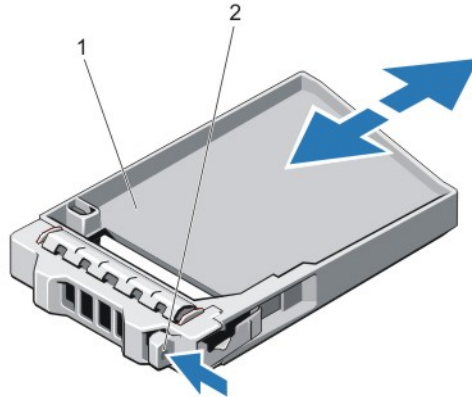
When you format a hard drive, allow enough time for the formatting to be completed. Be aware that high-capacity hard drives can take a number of hours to format.

**NOTE:** The following procedures apply to the hard drives in the enclosure. For server module-specific hard drives, see the server module's Owner's Manual at [Dell.com/poweredge manuals](http://Dell.com/poweredge manuals).

## Removing a 2.5 inch hard drive blank

**⚠ CAUTION:** To maintain proper system cooling, all empty hard drive slots must have hard drive blanks installed.

- 1 If installed, remove the front bezel.
- 2 Press the release button and slide the hard drive blank out until it is free of the hard drive slot.



**Figure 31. Removing and Installing a 2.5 Inch Hard-Drive Blank**

- |   |                  |   |                |
|---|------------------|---|----------------|
| 1 | hard drive blank | 2 | release button |
|---|------------------|---|----------------|

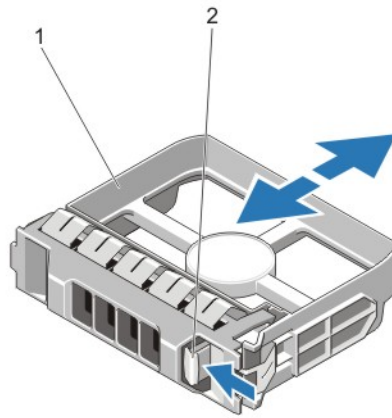
## Installing A 2.5 Inch Hard-Drive Blank

- 1 If installed, remove the front bezel.
- 2 Insert the hard drive blank into the hard drive slot until the release button clicks into place.
- 3 If applicable, install the front bezel.

## Removing a 3.5 inch hard drive blank

**⚠ CAUTION:** To maintain proper system cooling, all empty hard drive slots must have drive blanks installed.

- 1 If installed, remove the front bezel.
- 2 Grasp the front of the hard drive blank, press the release button and slide the blank out until it is free of the hard drive slot.



**Figure 32. Removing and installing a 3.5-inch hard drive blank**

- |   |                  |   |                |
|---|------------------|---|----------------|
| 1 | hard drive blank | 2 | release button |
|---|------------------|---|----------------|

## Installing a 3.5-inch hard drive blank

- 1 If installed, remove the front bezel.
- 2 Insert the hard drive blank into the hard drive slot until the release button clicks into place.
- 3 If applicable, install the front bezel.

## Removing a hot-swap hard drive

**⚠ CAUTION:** Before attempting to remove or install a hard drive while the system is running, see the documentation for the storage controller card to ensure that the host adapter is configured correctly to support hot-swap hard drive removal and insertion.

**⚠ CAUTION:** Do not turn off or reboot your system while the hard drive is being formatted. Doing so can cause a hard drive failure.

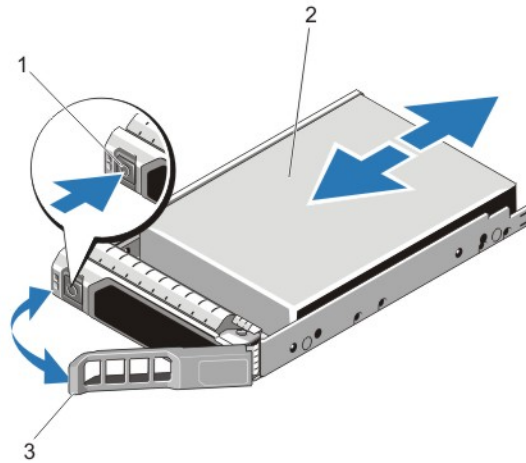
**⚠ CAUTION:** To prevent data loss, ensure that your operating system supports hot-swap drive installation. See the documentation supplied with your operating system.

- 1 If installed, remove the front bezel.
- 2 From the management software, prepare the hard drive for removal. Wait until the indicators on the hard drive carrier signal that the hard drive can be removed safely. For more information, see the documentation for the storage controller.  
If the hard drive is online, the green activity/fault indicator flashes as the drive is turned off. When the hard drive indicators are off, the hard drive is ready for removal.
- 3 Press the release button to open the hard drive carrier release handle.
- 4 Slide the hard drive carrier out until it is free of the hard drive slot.

**⚠ CAUTION:** To maintain proper system cooling, all empty hard drive slots must have hard drive blanks installed.

- 5 Insert a hard drive blank in the empty hard drive slot.





**Figure 33. Removing and installing a hot-swap hard drive**

- |   |                           |   |            |
|---|---------------------------|---|------------|
| 1 | release button            | 2 | hard drive |
| 3 | hard drive carrier handle |   |            |

## Installing a hot-swap hard drive

- △ **CAUTION:** Many repairs may only be done by a certified service technician. You should only perform troubleshooting and simple repairs as authorized in your product documentation, or as directed by the online or telephone service and support team. Damage due to servicing that is not authorized by Dell is not covered by your warranty. Read and follow the safety instructions that are shipped with your product.
- △ **CAUTION:** Use only hard drives that have been tested and approved for use with the hard drive backplane.
- △ **CAUTION:** When installing a hard drive, ensure that the adjacent drives are installed properly. Inserting a hard drive carrier and attempting to lock its handle next to a partially installed carrier can damage the partially installed carrier's shield spring and make it unusable.
- △ **CAUTION:** To prevent data loss, ensure that your operating system supports hot-swap drive installation. See the documentation supplied with your operating system.
- △ **CAUTION:** When a replacement hot swappable hard drive is installed and the system is powered on, the hard drive automatically begins to rebuild. Ensure that the replacement hard drive is blank or contains data that you wish to overwrite. Any data on the replacement hard drive is immediately lost after the hard drive is installed.

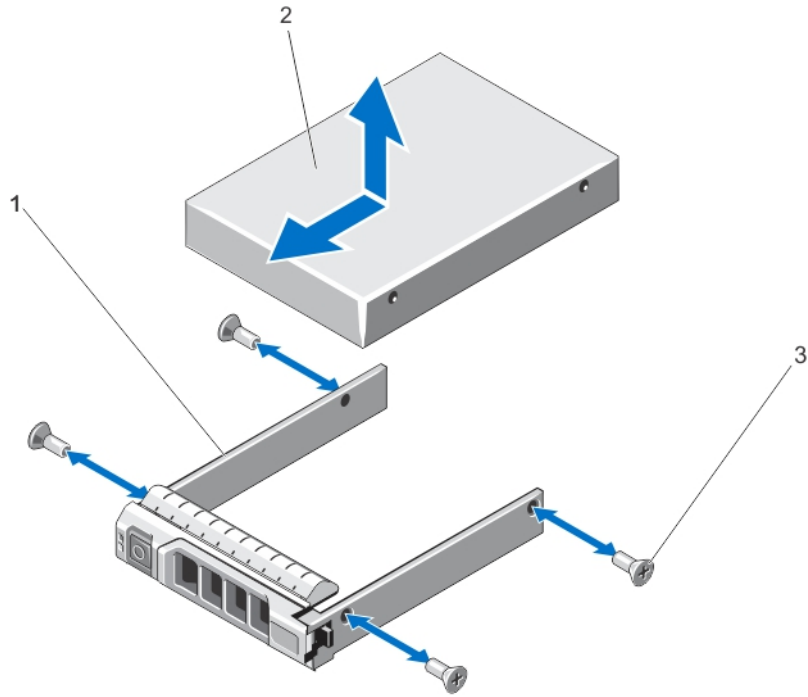
- 1 If installed, remove the front bezel.
- 2 If a hard drive blank is installed in the hard drive slot, remove it.
- 3 Install a hard drive in the hard drive carrier.
- 4 Press the release button on the front of the hard drive carrier and open the hard drive carrier handle.
- 5 Insert the hard drive carrier into the hard drive slot until the carrier connects with the backplane.
- 6 Close the hard drive carrier handle to lock the hard drive in place.
- 7 If applicable, install the front bezel.

## Removing a hard drive from a hard drive carrier

- 1 Remove the screws from the slide rails on the hard drive carrier.

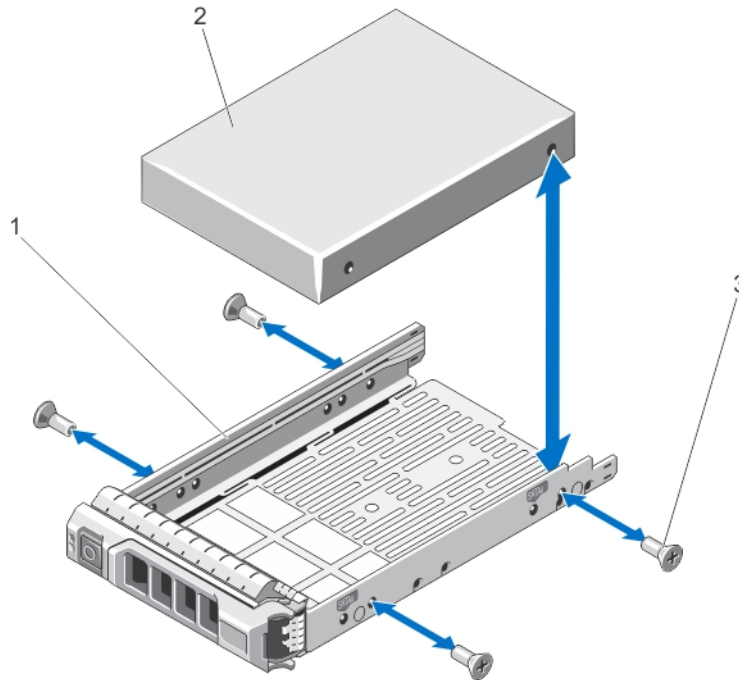
For the 2.5-inch hard drive, turn the hard drive carrier upside down, and remove the screws from the side rails on the hard drive carrier.

- 2 Lift the hard drive out of the hard drive carrier.



**Figure 34. Removing and installing a 2.5-inch hard drive into a hard drive carrier**

- |   |                    |   |            |
|---|--------------------|---|------------|
| 1 | hard drive carrier | 2 | hard drive |
| 3 | screws (4)         |   |            |



**Figure 35. Removing and installing a 3.5-inch hard drive into a hard drive carrier**

- 1 hard drive carrier
- 2 hard drive
- 3 screws (4)

## Installing a hard drive into a hard drive carrier

**⚠ CAUTION:** Many repairs may only be done by a certified service technician. You should only perform troubleshooting and simple repairs as authorized in your product documentation, or as directed by the online or telephone service and support team. Damage due to servicing that is not authorized by Dell is not covered by your warranty. Read and follow the safety instructions that are shipped with your product.

- 1 Insert the hard drive into the hard drive carrier with the connector end of the hard drive toward the back of the carrier.
- 2 Align the screw holes on the hard drive with the screws holes on the hard drive carrier.  
When aligned correctly, the back of the hard drive is flush with the back of the hard drive carrier.
- 3 Attach the screws to secure the hard drive to the hard drive carrier.

## Server modules

**① NOTE:** Your system supports server modules that are specifically configured for the enclosure, and can be identified by a label marked PCIe on the server module. If you install server modules that are not configured for the enclosure, an error message is displayed. For more information on configuring a server module for the enclosure, see [Configuring A Server Module](#).

**① NOTE:** Ensure that you have downloaded the latest BIOS on the server module(s) from [Dell.com/support](http://Dell.com/support).

# Removing a server module

- 1 If installed, remove the front bezel.
- 2 Turn off the server module using the operating system commands or the CMC.  
When a server module is powered off, its front panel power indicator is off.
- 3 Press the release button on the server module handle.
- 4 Pull out the server module handle to unlock the server module from the enclosure.

**CAUTION:** If you are permanently removing the server module, install a server module blank(s). Operating the system for an extended period of time without a server module blank installed can cause the enclosure to overheat.

- 5 Slide the server module out of the enclosure.

**CAUTION:** To protect the I/O connector pins, install the I/O connector covers every time a server module is removed from the enclosure.

- 6 Install the I/O connector cover(s) over the I/O connector(s).

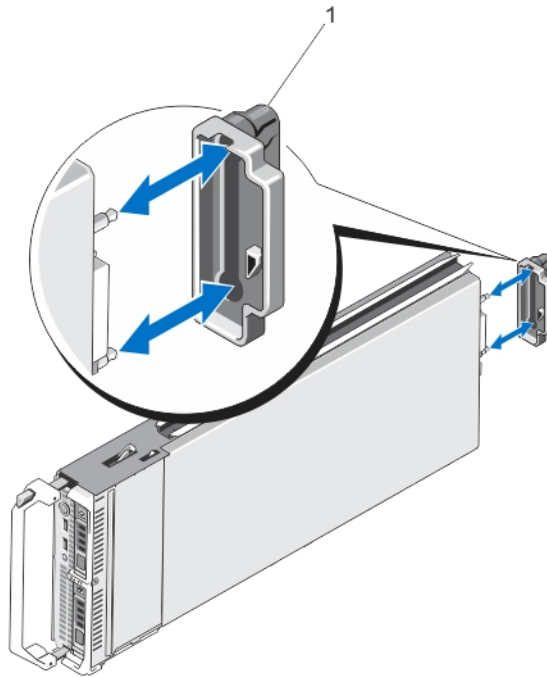
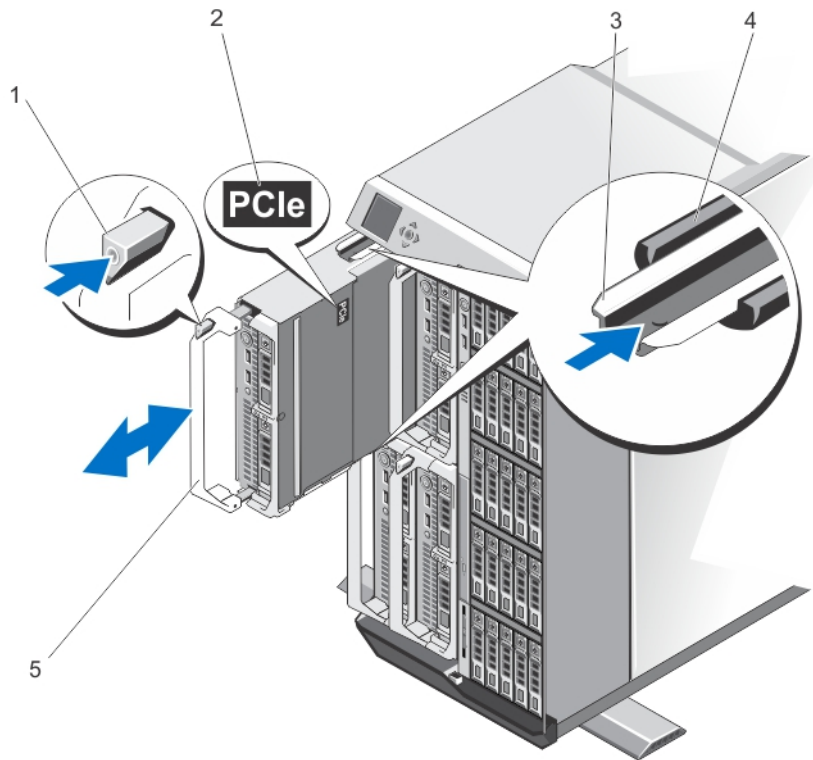


Figure 36. Removing and installing the I/O connector cover

- 1 I/O connector cover

**NOTE:** There are two I/O connector covers on the PowerEdge M820 server module.



**Figure 37. Removing and installing a server module**

- |   |  |
|---|--|
| <p>1 release button</p> <p>3 guide rail on server module (or server module blank)</p> <p>5 server module handle</p> | <p>2 <b>PCIe</b> label on server module</p> <p>4 guide rail on enclosure</p> |
|---|--|

**NOTE:** This label indicates that the server module is configured specifically for the VRTX enclosure.

**NOTE:** The above figure shows removal and installation of a half-height server module. The procedure for removing and installing a full-height server module is identical to removing and installing a half-height server module.

## Configuring a server module

**NOTE:** Follow this procedure to install server modules that are not configured for the VRTX enclosure.

**NOTE:** If you install server modules that are not configured for the VRTX enclosure, an error message is displayed.

To configure a server module for the VRTX enclosure:

- 1 Open the server module.  
For more information about opening a server module, see the server module Owner's Manual at [Dell.com/poweredge manuals](http://Dell.com/poweredge manuals).
- 2 Remove any mezzanine cards installed in Fabric B and Fabric C slots of the server module.
- 3 Install PCIe Mezzanine cards in the vacant Fabric B and Fabric C slots.  
For more information about installing the PCIe Mezzanine cards, see the server module Owner's Manual at [Dell.com/poweredge manuals](http://Dell.com/poweredge manuals).
- 4 Ensure that no tools or parts are left inside the server module.
- 5 Slide the cover on the server module until it clicks into position.  
A properly seated cover is flush with the surface of the server module chassis.

- 6 Install the latest iDRAC Enterprise license. For more information, see the *iDRAC7 User's Guide*, at [Dell.com/idracmanuals](http://Dell.com/idracmanuals).

## Installing a server module

Your system supports server modules that are specifically configured for the PowerEdge VRTX enclosure, and can be identified by a label marked **PCIe** on the top of the server module.

**NOTE:** To install full-height server module(s), you must remove the server module partitions. For more information, see [Removing The Server Module Partitions](#).

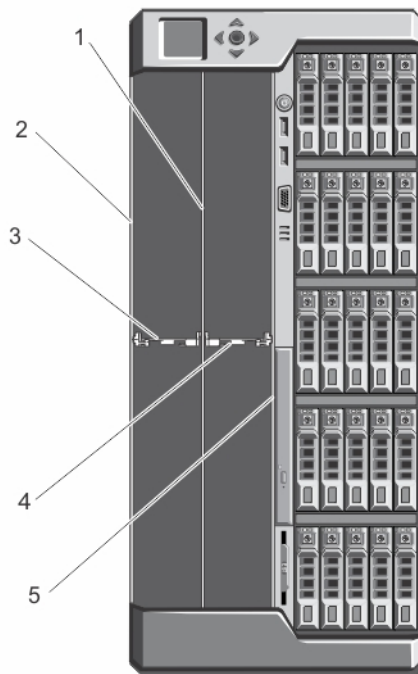
- 1 If you are installing a new server module, remove the plastic cover(s) from the I/O connector(s) and save for future use.
- 2 If applicable, configure the server module. For more information, see [Configuring A Server Module](#).
- 3 Orient the server module so that the module handle is on the left side of the server module.
- 4 Align the server module with the server module slot and guide rails on the enclosure.
- 5 Using both hands, slide the server module into the enclosure until the module release handle engages and locks the server module in place.
- 6 If applicable, reinstall the front bezel.

## Server module partitions

You must remove the server module partitions to install full-height server modules in the PowerEdge VRTX enclosure.

You must install the server module partition to:

- Install half-height server modules in the enclosure.
- Install server module blanks.



**Figure 38. Server module partitions**

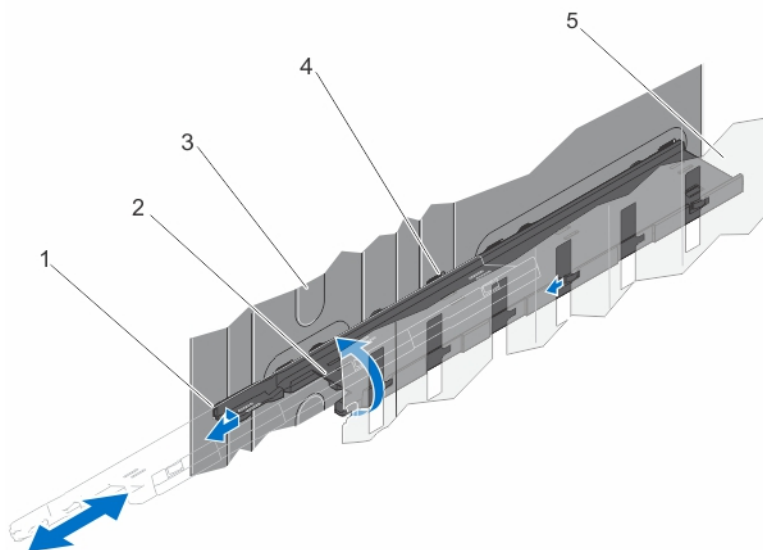
- |   |   |   |   |
|---|---|---|---|
| 1 | metal partition                               | 2 | outer chassis wall                            |
| 3 | server module partition between Slots 1 and 3 | 4 | server module partition between Slots 2 and 4 |

## Removing the server module partitions

**CAUTION:** Many repairs may only be done by a certified service technician. You should only perform troubleshooting and simple repairs as authorized in your product documentation, or as directed by the online or telephone service and support team. Damage due to servicing that is not authorized by Dell is not covered by your warranty. Read and follow the safety instructions that are shipped with your product.

**NOTE:** You must remove the server module partitions to install full-height server modules.

- 1 If installed, remove the front bezel.
- 2 Turn off the server modules using the operating system commands or the CMC.
- 3 Turn off the enclosure, including any attached peripherals, and disconnect the enclosure from the electrical outlet.
- 4 Remove the server modules or server module blanks.
- 5 To remove the server module partition between Slots 1 and 3:
  - a Hold the release tab on the server module partition and pull it out from the chassis wall to disengage the locking tab from the slot on the chassis wall.
  - b Holding the release tab, pull the partition toward the front of the system until it stops sliding. The tabs on the partition move to unlock position.
  - c Rotate the partition upward in the counter-clockwise direction to disengage the tabs from the slots on the metal partition.
  - d Slide the partition out from the system, and save for future use.

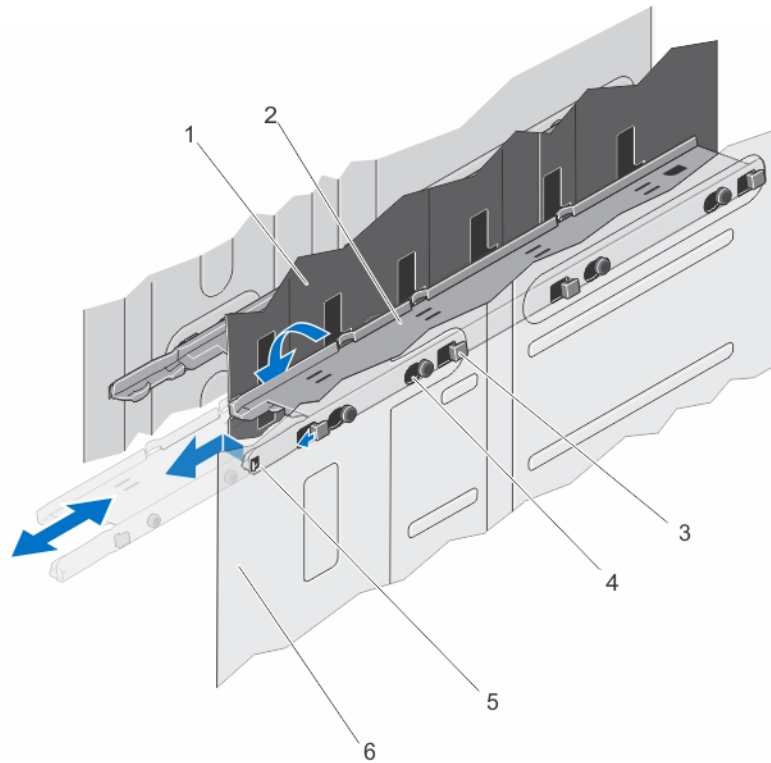


**Figure 39. Removing and installing the server module partition between slots 1 and 3**

- |  |                                       |
|--|---------------------------------------|
| 1 locking tab on server module partition | 2 server module partition             |
| 3 outer chassis wall                     | 4 tabs on the server module partition |
| 5 metal partition                        |                                       |

- 6 To remove the server module partition between Slots 2 and 4:
  - a Hold the release tab on the server module partition and pull it out from the chassis wall to disengage the locking tab from the chassis slot.
  - b Holding the release tab, pull the partition toward the front of the system until it stops sliding. The tabs on the partition move to unlock position.

- c Rotate the partition downward in the counter-clockwise direction to disengage the tabs from the slots on the metal partition.
- d Slide the partition out from the system, and save for future use.



**Figure 40. Removing and installing the server module partition between slots 2 and 4**

- |   |  |   |                                 |
|---|--|---|---------------------------------|
| 1 | metal partition                        | 2 | server module partition         |
| 3 | tabs on the server module partition    | 4 | slots on the inner chassis wall |
| 5 | locking tab on server module partition | 6 | inner chassis wall              |

- 7 Install the server modules.
- 8 Reconnect the enclosure to the electrical outlet and turn the enclosure on, including any attached peripherals.
- 9 Turn on the server modules using the operating system commands or the CMC.
- 10 If applicable, install the front bezel.

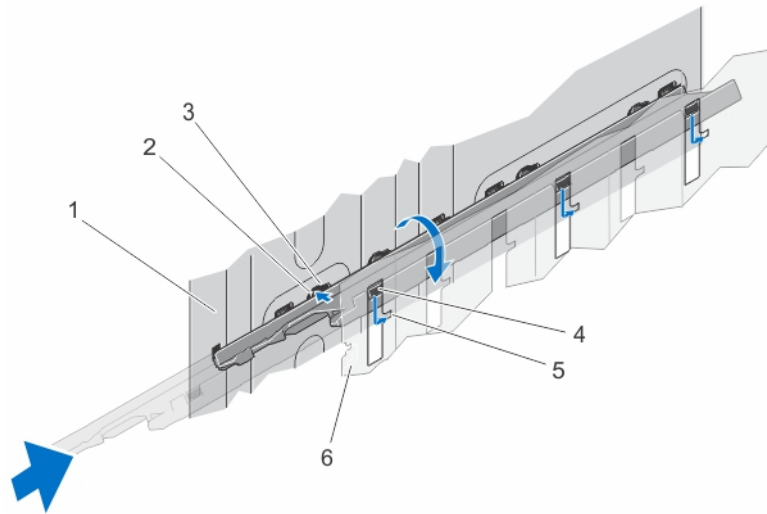
## Installing the server module partitions

**CAUTION:** Many repairs may only be done by a certified service technician. You should only perform troubleshooting and simple repairs as authorized in your product documentation, or as directed by the online or telephone service and support team. Damage due to servicing that is not authorized by Dell is not covered by your warranty. Read and follow the safety instructions that are shipped with your product.

- 1 If installed, remove the front bezel.
- 2 Turn off the server modules using the operating system commands or the CMC.
- 3 Turn off the enclosure, including any attached peripherals, and disconnect the enclosure from the electrical outlet and peripherals.
- 4 Remove the server modules or server module blanks.
- 5 To install the server module partition between Slots 1 and 3:
  - a Angle the partition and slide it into the chassis.
  - b Align the tabs on the partition with the slots on the outer chassis wall and insert the tabs into the slots.
  - c Rotate the partition downward in the clockwise direction until the tabs on the other side of the partition engage with the slots on the metal partition.



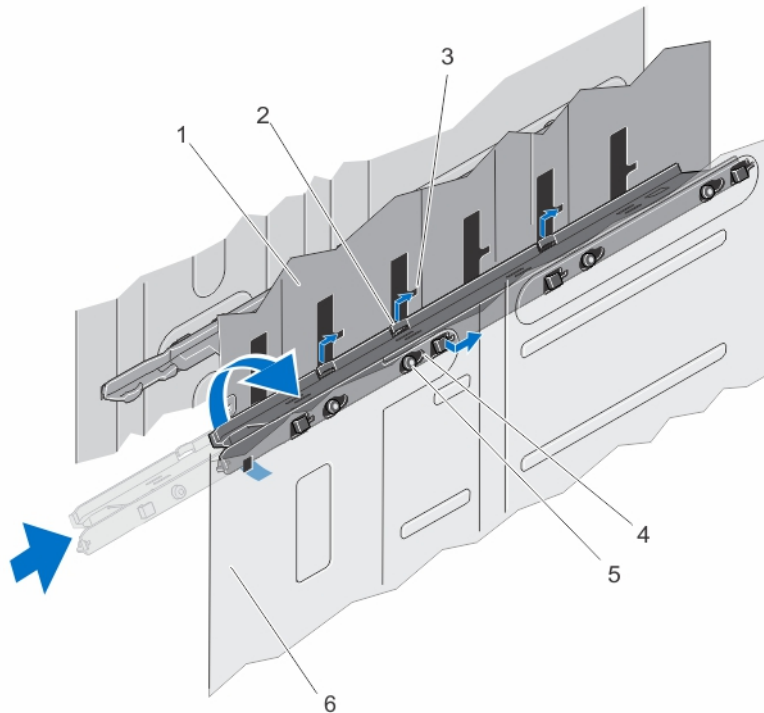
- d Slide the partition toward the back of the system until the release tab on the partition engages with the slot on the chassis wall.



**Figure 41. Installing the server module partition between slots 1 and 3**

- |   |                                     |   |                                 |
|---|-------------------------------------|---|---------------------------------|
| 1 | outer chassis wall                  | 2 | tabs on server module partition |
| 3 | slots on the outer chassis wall     | 4 | slots on the metal partition    |
| 5 | tabs on the server module partition | 6 | metal partition                 |

- 6 To install the server module partition between Slots 2 and 4:
  - a Angle the partition and slide it into the chassis.
  - b Align the tabs on the partition with the slots on the inner chassis wall and insert the tabs into the slots.
  - c Rotate the partition upward in the clockwise direction until the tabs on the other side of the partition engage with the slots on the metal partition.
  - d Slide the partition toward the back of the system until the release tab on the partition engages with the slot on the chassis wall.



**Figure 42. Installing the server module partition between slots 2 and 4**

- |   |                                     |   |                                 |
|---|-------------------------------------|---|---------------------------------|
| 1 | metal partition                     | 2 | tabs on server module partition |
| 3 | slots on the metal partition        | 4 | slots on the inner chassis wall |
| 5 | tabs on the server module partition | 6 | inner chassis wall              |

- 7 Install the server modules.
- 8 Reconnect the enclosure to its electrical outlet and turn the enclosure on, including any attached peripherals.
- 9 Turn on the server modules using the operating system commands or the CMC.
- 10 If applicable, install the front bezel.

## Power supply units

Your system supports up to four 1100 W or 1600 W AC power supply units (PSUs) in 3+1 and 2+2 redundant configurations.

**⚠ CAUTION: Unsupported PSU configurations can result in a PSU mismatch condition and failure to power on.**

**① NOTE: Ensure all PSU are of the same rated output capacity, generation, and input voltage.**

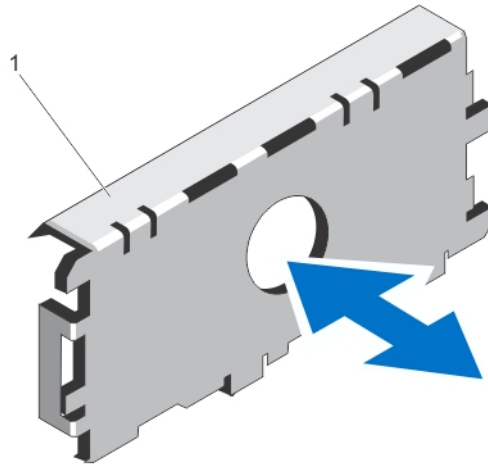
**① NOTE: Unsupported PSU configurations are 2 or more PSUs that do not share the same supported model, rated output capacity, generation, or input voltage.**

**① NOTE: In the 2+2 redundant configuration, PSU1 and PSU2 are connected to one grid, and PSU3 and PSU4 are connected to another grid.**

## Power supply unit blanks

If the enclosure is operated with less than four power supply units (PSUs), PSU blanks must be installed in the unoccupied PSU bays to maintain proper cooling airflow in the enclosure.

To remove the PSU blank in the bay, pull outward on the blank.



**Figure 43. Removing and installing a PSU blank**

1 PSU blank

Align the PSU blank with the PSU bay, and insert it into the chassis until it clicks into place.

## Removing a power supply unit

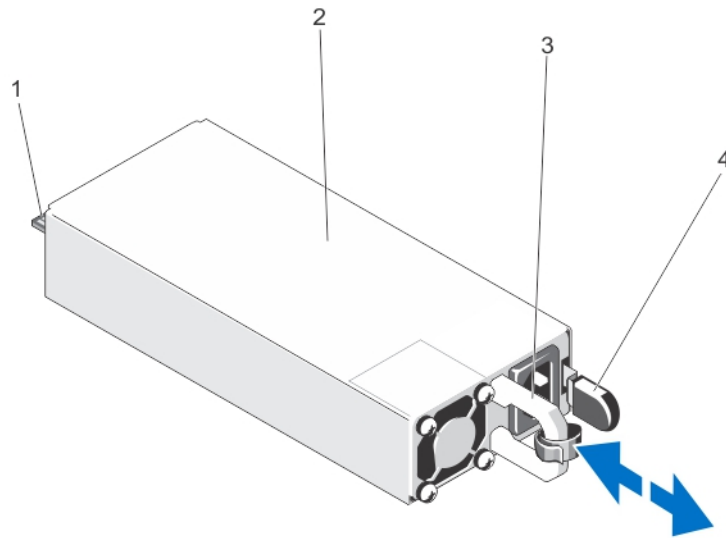
**⚠ CAUTION:** Many repairs may only be done by a certified service technician. You should only perform troubleshooting and simple repairs as authorized in your product documentation, or as directed by the online or telephone service and support team. Damage due to servicing that is not authorized by Dell is not covered by your warranty. Read and follow the safety instructions that are shipped with your product.

**ⓘ NOTE:** The power supply units (PSUs) are hot-swappable. Remove and replace only one PSU at a time in a system that is turned on.

**ⓘ NOTE:** In systems that ship with the wheel assembly, a power cable retention bracket is used to route the power cable from the PSU

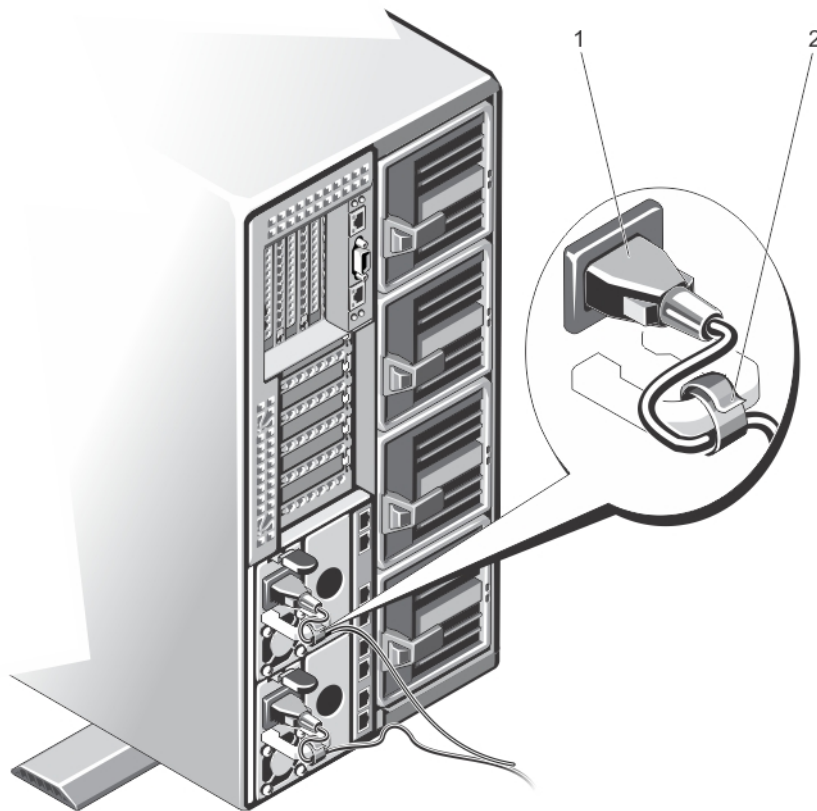
**ⓘ NOTE:** To switch to a new PSU rated output capacity, generation, or input voltage, you must first power down the chassis before changing the PSU configuration.

- 1 Disconnect the power cable from the power source and the PSU you intend to remove.
  - a In systems without the wheel assembly installed, remove the power cable from the cable strap.
  - b In systems with the wheel assembly installed, remove the power cable from the power cable retention bracket slot.
- 2 Press the release latch and slide the PSU out of the chassis.



**Figure 44. Removing and installing a PSU**

- |   |            |   |               |
|---|------------|---|---------------|
| 1 | connector  | 2 | PSU           |
| 3 | PSU handle | 4 | release latch |



**Figure 45. Securing the power cable (without wheel assembly)**

- |   |             |   |       |
|---|-------------|---|-------|
| 1 | power cable | 2 | strap |
|---|-------------|---|-------|

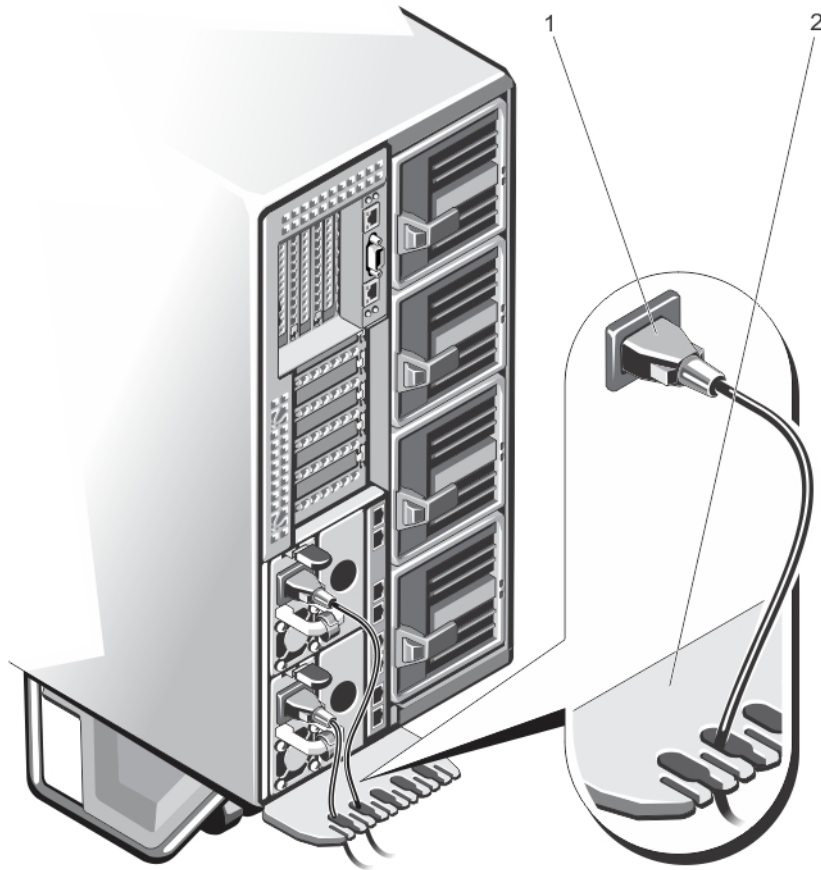


Figure 46. Securing the power cable (with wheel assembly)

1 power cable

2 power cable retention bracket

## Installing a power supply

**CAUTION:** Many repairs may only be done by a certified service technician. You should only perform troubleshooting and simple repairs as authorized in your product documentation, or as directed by the online or telephone service and support team. Damage due to servicing that is not authorized by Dell is not covered by your warranty. Read and follow the safety instructions that are shipped with your product.

- 1 If applicable, remove the power supply blank.
- 2 Slide the new power supply into the enclosure until the power supply is fully seated and the release latch snaps into place.
- 3 Connect the power cable to the power supply and plug the cable into a power outlet.
  - a In systems without the wheel assembly installed, secure the power cable with the strap.
  - b In systems with the wheel assembly installed, route the power cable from the power supply through the power cable retention bracket, by sliding it into one of the slots on the bracket.

**NOTE:** When installing, hot-swapping, or hot-adding a new power supply, allow several seconds for the system to recognize the power supply and determine its status. The power supply status indicator turns green to indicate that the power supply is functioning properly.

# Cooling shroud

## Removing the cooling shroud

**CAUTION:** Many repairs may only be done by a certified service technician. You should only perform troubleshooting and simple repairs as authorized in your product documentation, or as directed by the online or telephone service and support team. Damage due to servicing that is not authorized by Dell is not covered by your warranty. Read and follow the safety instructions that are shipped with your product.

**CAUTION:** Never operate your system with the air shroud removed. The system may get overheated quickly, resulting in shutdown of the system and loss of data.

- 1 If installed, remove the front bezel.
- 2 Turn off the server modules using the operating system commands or the CMC.
- 3 Turn off the enclosure, including any attached peripherals, and disconnect the enclosure from the electrical outlet and peripherals.
- 4 To reduce the chassis weight, remove the following (if required):
  - a hard drives
  - b server modules
  - c power supplies
- 5 If applicable, rotate the system feet inward and lay the system on its side on a flat stable surface, with the cover release latch side on top.
- 6 Open the system.
- 7 Holding it by the edges, disengage the shroud from the release pins on the hard drive backplane, and lift the shroud away from the system.

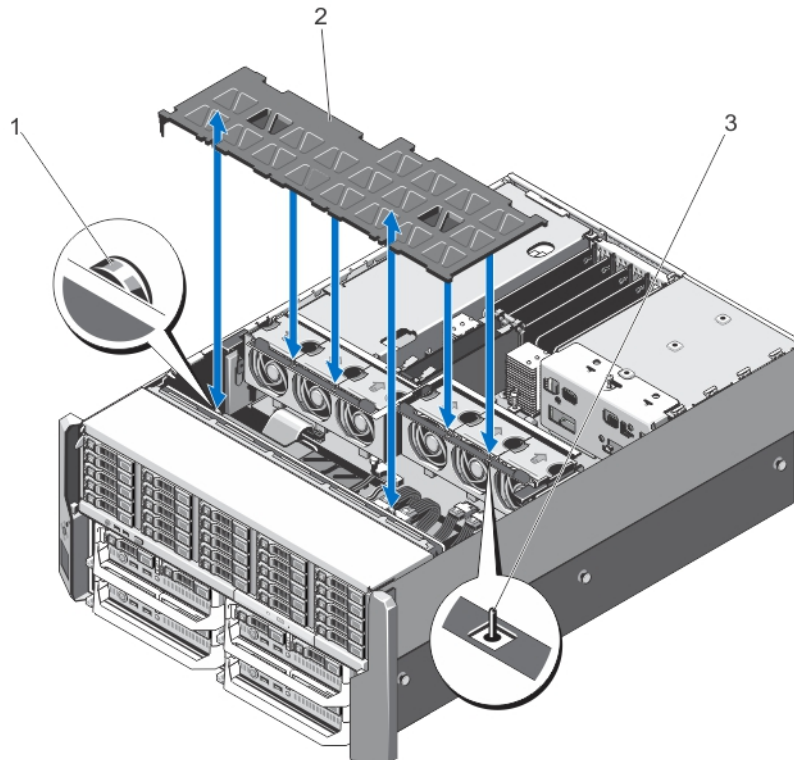


Figure 47. Removing and installing the cooling shroud

1 release pins on the hard drive backplane (2)

2 cooling shroud

## Installing the cooling shroud

**CAUTION:** Many repairs may only be done by a certified service technician. You should only perform troubleshooting and simple repairs as authorized in your product documentation, or as directed by the online or telephone service and support team. Damage due to servicing that is not authorized by Dell is not covered by your warranty. Read and follow the safety instructions that are shipped with your product.

- 1 Align the slot on the cooling shroud with the pin on the cooling fan assembly.  
When aligned, the slots on the other edge of the shroud align with the release pins on the hard drive backplane.
- 2 Lower the cooling shroud into the chassis.
- 3 Press down the shroud over the release pins on the hard drive backplane, until it is firmly seated.
- 4 Close the system.
- 5 If applicable, place the system upright on a flat, stable surface and rotate the system feet outward.
- 6 If removed, reinstall the hard drives, server modules, and power supplies.
- 7 Reconnect the enclosure to its electrical outlet and turn the enclosure on, including any attached peripherals.
- 8 Turn on the server modules using the operating system commands or the CMC.
- 9 If applicable, install the front bezel.

## Cooling fans

Your system supports six hot-swappable cooling fans that provide cooling to the storage and I/O components in the enclosure.

To provide increased cooling to the storage and PCIe components in the chassis, you can set the fan configuration to **Fan Offset** in the CMC web interface.

For more information about the **Fan Offset** option, see “Advanced Fan Configuration” in the *CMC Online Help*.

**NOTE:** In the event of a problem with a particular fan, the fan number is referenced by the system’s management software, allowing you to easily identify and replace the appropriate fan by noting the fan numbers on the cooling fan assembly.

## Removing a cooling fan

**WARNING:** Opening or removing the system cover when the system is on may expose you to a risk of electric shock. Exercise utmost care while removing or installing cooling fans.

**WARNING:** The cooling fan can continue to spin for some time after it has been powered down. Allow time for the fan to stop spinning before removing it from the system.

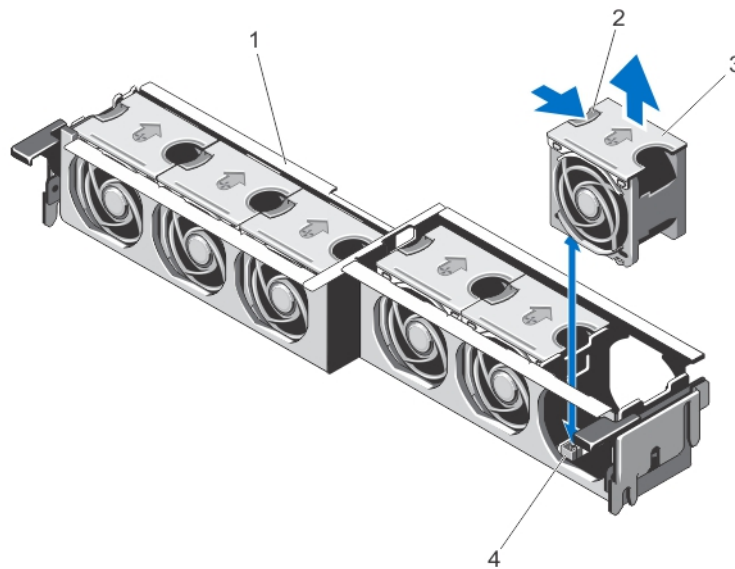
**CAUTION:** Many repairs may only be done by a certified service technician. You should only perform troubleshooting and simple repairs as authorized in your product documentation, or as directed by the online or telephone service and support team. Damage due to servicing that is not authorized by Dell is not covered by your warranty. Read and follow the safety instructions that are shipped with your product.

**CAUTION:** To maintain optimum thermal conditions, ensure that there are no obstructions to airflow on the front and back of the enclosure. The front and back of the enclosure must have at least 30 cm (12-inches) and 61 cm (24 inches) of unobstructed space respectively.

**CAUTION:** The cooling fans are hot-swappable. To maintain proper cooling while the system is on, replace only one fan at a time.

**NOTE:** The procedure for removing each fan is identical.

- 1 Open the system.
- 2 Press the fan release tab and lift the cooling fan out of the cooling fan assembly.



**Figure 48. Removing and installing a cooling fan**

- |   |                      |   |                            |
|---|----------------------|---|----------------------------|
| 1 | cooling fan assembly | 2 | fan release tab            |
| 3 | cooling fans (6)     | 4 | cooling fan connectors (6) |

## Installing a cooling fan

**CAUTION:** Many repairs may only be done by a certified service technician. You should only perform troubleshooting and simple repairs as authorized in your product documentation, or as directed by the online or telephone service and support team. Damage due to servicing that is not authorized by Dell is not covered by your warranty. Read and follow the safety instructions that are shipped with your product.

- 1 Align the plug at the base of the cooling fan with the connector on the system board.
- 2 Slide the cooling fan into the securing slots until the tabs lock into place.
- 3 Close the system.

## Cooling fan assembly

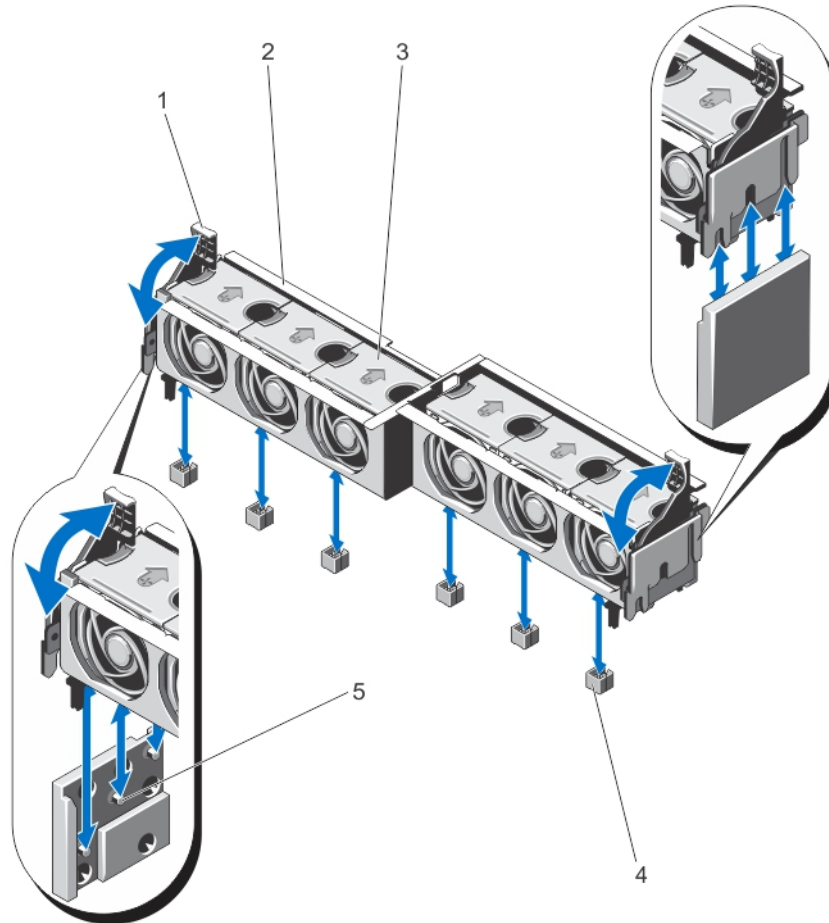
## Removing the cooling fan assembly

**CAUTION:** Many repairs may only be done by a certified service technician. You should only perform troubleshooting and simple repairs as authorized in your product documentation, or as directed by the online or telephone service and support team. Damage due to servicing that is not authorized by Dell is not covered by your warranty. Read and follow the safety instructions that are shipped with your product.

- 1 If installed, remove the front bezel.
- 2 Turn off the server modules using the operating system commands or the CMC.
- 3 Turn off the enclosure, including any attached peripherals, and disconnect the enclosure from the electrical outlet and peripherals.
- 4 To reduce the chassis weight, remove the following (if required):
  - a hard drives
  - b server modules
  - c power supplies



- 5 If applicable, rotate the system feet inward and lay the system on its side on a flat stable surface, with the cover release latch side on top.
- 6 Open the system.
- 7 Remove the cooling shroud.
- 8 Unlock the cooling fan assembly from the chassis by rotating the release levers upward.
- 9 Lift the cooling fan assembly out of the chassis.



**Figure 49. Removing and installing the cooling fan assembly**

- |   |                      |   |                            |
|---|----------------------|---|----------------------------|
| 1 | release levers (2)   | 2 | cooling fan assembly       |
| 3 | cooling fans (6)     | 4 | cooling fan connectors (6) |
| 5 | support brackets (2) |   |                            |

## Installing the cooling fan assembly

**⚠ CAUTION:** Many repairs may only be done by a certified service technician. You should only perform troubleshooting and simple repairs as authorized in your product documentation, or as directed by the online or telephone service and support team. Damage due to servicing that is not authorized by Dell is not covered by your warranty. Read and follow the safety instructions that are shipped with your product.

- 1 Align the cooling fan assembly with the support brackets on the sides of the chassis, and the guide pin on the chassis base.
- 2 Slide the cooling fan assembly into the chassis.
- 3 Lock the cooling fan assembly into the chassis by rotating the blue release levers downward until firmly seated.

- 4 Reinstall the cooling shroud.
- 5 Close the system.
- 6 If applicable, place the system upright on a flat, stable surface and rotate the system feet outward.
- 7 If removed, reinstall the hard drives, server modules, and power supply units.
- 8 Reconnect the enclosure to its electrical outlet and turn the enclosure on, including any attached peripherals.
- 9 Turn on the server modules using the operating system commands or the CMC.
- 10 If applicable, install the front bezel.

## Blower modules

Your system supports four hot-swappable blower modules to ensure proper cooling of the server modules.

To provide increased cooling for the server modules in the enclosure, you can set the blower configuration to the **Enhanced Cooling Mode** (ECM) in the CMC web interface. Disabled ECM may reduce upper ambient temperature support on certain system configurations. ECM should be enabled for the following conditions:

- PowerEdge M630 systems populated with processors of 120 W or more
- PowerEdge M630 systems deployed in environments where the temperature exceeds 30°C
- Any server module configuration operating in a fresh-air environment

For more information about the **Enhanced Cooling Mode** option, see “Advanced Fan Configuration” in the CMC *Online Help*, and the PowerEdge VRTX CMC User’s Guide at [Dell.com/esmmanuals](http://Dell.com/esmmanuals).

## Removing a blower module

**⚠ WARNING:** Do not operate the system without the blower modules.

**⚠ CAUTION:** While replacing a blower module when the enclosure is on, ensure that you install the replacement blower module within 30 seconds to prevent cooling problems.

**⚠ CAUTION:** Exercise care while handling the blower module to prevent damage to the connector on the blower module.

**⚠ CAUTION:** Many repairs may only be done by a certified service technician. You should only perform troubleshooting and simple repairs as authorized in your product documentation, or as directed by the online or telephone service and support team. Damage due to servicing that is not authorized by Dell is not covered by your warranty. Read and follow the safety instructions that are shipped with your product.

**⚠ CAUTION:** The blower closeout door is spring loaded. To prevent injury, exercise care when placing your hand or fingers inside the blower module bay.

**⚠ CAUTION:** To maintain optimum thermal conditions, ensure that there are no obstructions to airflow on the front and back of the enclosure. The front and back of the enclosure must have at least 30 cm (12-inches) and 61 cm (24 inches) of unobstructed space respectively.

- 1 Identify the failed blower module using the back panel blower module indicators.
- 2 Press the release tab on the blower module handle and slide the blower module out of the chassis.

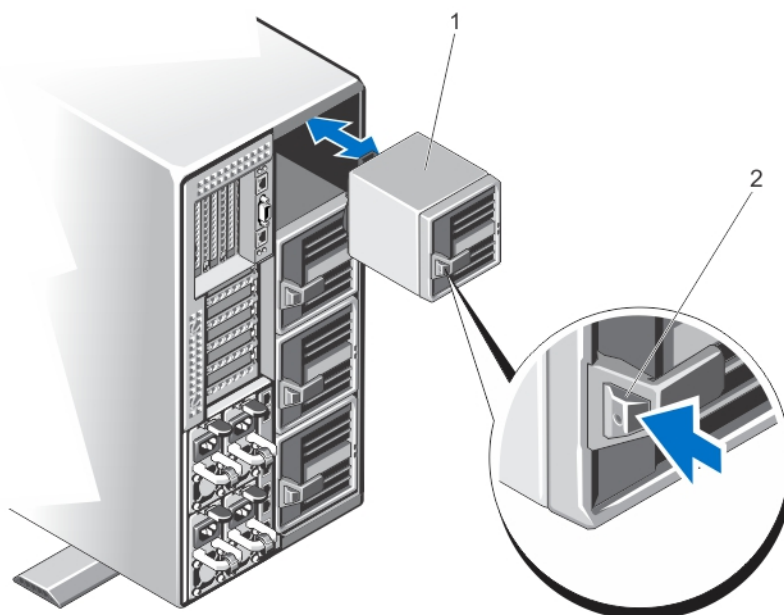


Figure 50. Removing and installing a blower module

1 blower module

2 release tab

## Installing a blower module

**CAUTION:** Many repairs may only be done by a certified service technician. You should only perform troubleshooting and simple repairs as authorized in your product documentation, or as directed by the online or telephone service and support team. Damage due to servicing that is not authorized by Dell is not covered by your warranty. Read and follow the safety instructions that are shipped with your product.

**CAUTION:** Exercise care while handling the blower module to prevent damage to the connector on the blower module.

**CAUTION:** The blower closeout door is spring loaded. To prevent injury, exercise care when placing your hand or fingers inside the blower module bay.

**CAUTION:** When replacing a blower module when the enclosure is on, install the replacement blower module within 30 seconds to prevent server module cooling problems.

- 1 Align the blower module with the slot on the chassis.
- 2 Holding the blower module by its handle, slide it into the chassis until it clicks into the slot and is fully seated.

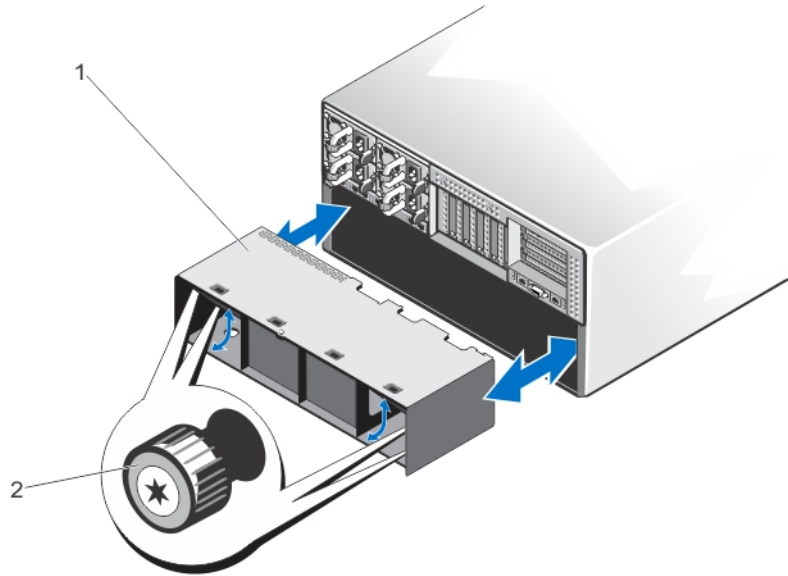
## Removing the blower module bay

**CAUTION:** Many repairs may only be done by a certified service technician. You should only perform troubleshooting and simple repairs as authorized in your product documentation, or as directed by the online or telephone service and support team. Damage due to servicing that is not authorized by Dell is not covered by your warranty. Read and follow the safety instructions that are shipped with your product.

**CAUTION:** The blower closeout door is spring loaded. To prevent injury, exercise care when placing your hand or fingers inside the blower module bay.

- 1 If installed, remove the front bezel.
- 2 Turn off the server modules using the operating system commands or the CMC.
- 3 Turn off the enclosure, including any attached peripherals, and disconnect the enclosure from the electrical outlet and peripherals.

- 4 Remove the four blower modules.
- 5 Loosen the four screws securing the blower module bay to the chassis.
- 6 Pull the blower module bay out of the chassis.



**Figure 51. Removing and installing the blower module bay**

1 blower module bay

2 screws (4)

## Installing the blower module bay

**CAUTION:** Many repairs may only be done by a certified service technician. You should only perform troubleshooting and simple repairs as authorized in your product documentation, or as directed by the online or telephone service and support team. Damage due to servicing that is not authorized by Dell is not covered by your warranty. Read and follow the safety instructions that are shipped with your product.

**CAUTION:** The blower closeout door is spring loaded. To prevent injury, exercise care when placing your hand or fingers inside the blower module bay.

- 1 Align the blower module bay with the slot on the back of the enclosure, and slide it in until it aligns with the screw holes on the chassis and is firmly seated.
- 2 Tighten the four screws to secure the blower module bay to the chassis.
- 3 Reinstall the blower modules.
- 4 Reconnect the enclosure to its electrical outlet and turn the enclosure on, including any attached peripherals.
- 5 Turn on the server modules using the operating system commands or the CMC.
- 6 If applicable, install the front bezel.

# I/O module

## Removing the I/O module

**CAUTION:** Many repairs may only be done by a certified service technician. You should only perform troubleshooting and simple repairs as authorized in your product documentation, or as directed by the online or telephone service and support team. Damage due to servicing that is not authorized by Dell is not covered by your warranty. Read and follow the safety instructions that are shipped with your product.

- 1 Disconnect the cables attached to the I/O module.
- 2 Loosen the retention screw securing the I/O module to the chassis.  
The I/O module connector disengages from the connector on the midplane.
- 3 Slide the I/O module out of the enclosure.

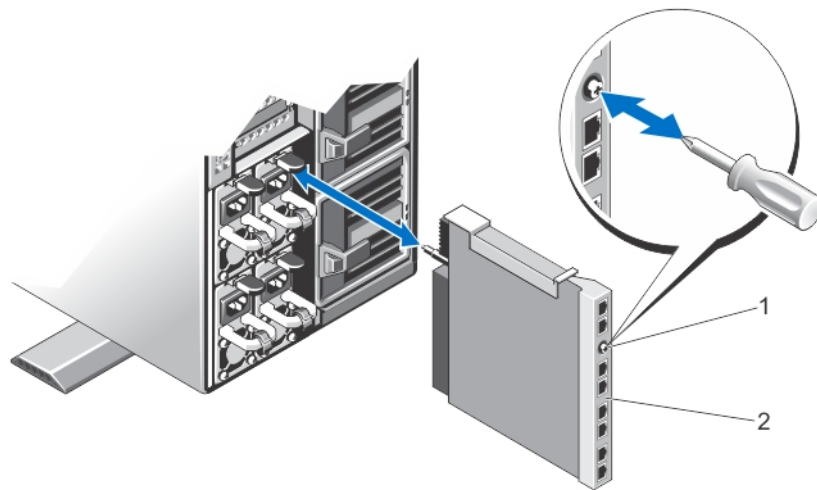


Figure 52. Removing and installing the I/O module

1 retention screw

2 I/O module

## Installing the I/O module

**CAUTION:** Many repairs may only be done by a certified service technician. You should only perform troubleshooting and simple repairs as authorized in your product documentation, or as directed by the online or telephone service and support team. Damage due to servicing that is not authorized by Dell is not covered by your warranty. Read and follow the safety instructions that are shipped with your product.

- 1 Unpack the I/O module and prepare it for installation.  
For instructions, see the documentation that accompanied the I/O module.
- 2 Remove the I/O connector cover.
- 3 Align the I/O module connector with the midplane connector, and slide the module in.

**NOTE:** The I/O module is not firmly seated at this stage.

**CAUTION:** Do not overtighten the retention screw when installing the I/O module. To prevent over-tightening, tighten the retention screw until resistance is felt and the screw is seated. The screw tension can range from 5 in-lb to 8 in-lb (5.7 kg-cm to 9.2 kg-cm).

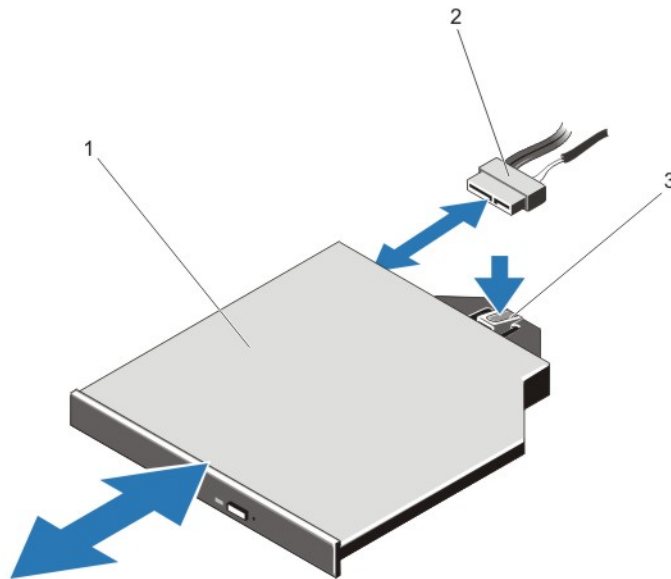
- 4 Tighten the retention screw until the I/O module connector engages with the connector on the midplane, and the I/O module is firmly seated.
- 5 Connect all cables that must be attached to the I/O module.  
See the documentation of the I/O module for information about its cable connections.

## Optical drive (optional)

### Removing the optional optical drive

**⚠ CAUTION:** Many repairs may only be done by a certified service technician. You should only perform troubleshooting and simple repairs as authorized in your product documentation, or as directed by the online or telephone service and support team. Damage due to servicing that is not authorized by Dell is not covered by your warranty. Read and follow the safety instructions that are shipped with your product.

- 1 If installed, remove the front bezel.
- 2 Turn off the server modules using the operating system commands or the CMC.
- 3 Turn off the enclosure, including any attached peripherals, and disconnect the enclosure from the electrical outlet and peripherals.
- 4 To reduce the chassis weight, remove the following (if required):
  - a hard drives
  - b server modules
  - c power supply units (PSUs)
- 5 If applicable, rotate the system feet inward and lay the system on its side on a flat stable surface, with the cover release latch side on top.
- 6 Open the system.
- 7 Remove the cooling shroud.
- 8 Remove the cooling fan assembly.
- 9 Remove the SAS cables and the backplane expander board. See [Removing The Backplane Expander Board](#).  
For the 3.5-inch hard drive chassis, remove the hard drives and the hard drive backplane. See [Removing The Hard-Drive Backplane](#).
- 10 Disconnect the power and data cable from the system board.
- 11 Disconnect the power and data cable from the back of the optical drive.  
Note the routing of the power and data cables as you remove them from the system board and the optical drive. You must route these cables properly when you replace them to prevent them from being pinched or crimped.
- 12 To release the optical drive, press and push the release tab toward the front of the enclosure.
- 13 Slide the optical drive out of the enclosure until it is free of the optical-drive slot.
- 14 If you are not adding a new optical drive, install the optical-drive blank.
- 15 Reinstall the backplane expander board and connect the SAS cables. See [Installing The Backplane Expander Board](#).  
For the 3.5-inch hard drive chassis, reinstall the hard drive backplane. See [Installing The Hard-Drive Backplane](#).
- 16 Reinstall the cooling fan assembly.
- 17 Reinstall the cooling shroud.
- 18 Close the system.
- 19 If applicable, place the system upright on a flat, stable surface and rotate the system feet outward.
- 20 If removed, reinstall the hard drives, server modules, and PSUs.
- 21 Reconnect the enclosure to its electrical outlet and turn the enclosure on, including any attached peripherals.
- 22 Turn on the server modules using the operating system commands or the CMC.
- 23 If applicable, install the front bezel.



**Figure 53. Removing and installing the optical drive**

- |  |  |
|--|--|
| <ul style="list-style-type: none"> <li>1 optical drive</li> <li>3 release tab</li> </ul> | <ul style="list-style-type: none"> <li>2 power and data cable</li> </ul> |
|--|--|

## Installing the optional optical drive

**CAUTION:** Many repairs may only be done by a certified service technician. You should only perform troubleshooting and simple repairs as authorized in your product documentation, or as directed by the online or telephone service and support team. Damage due to servicing that is not authorized by Dell is not covered by your warranty. Read and follow the safety instructions that are shipped with your product.

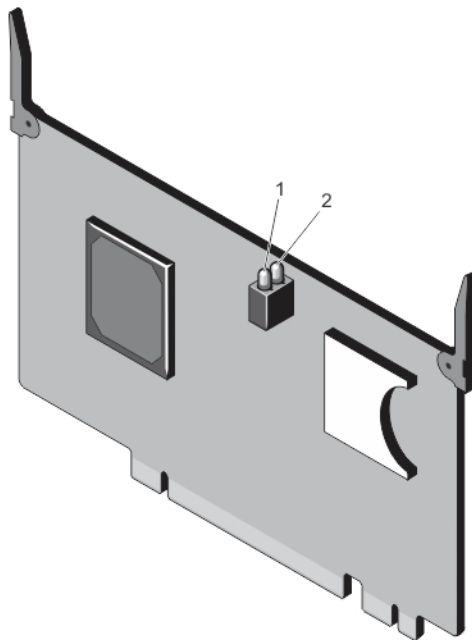
- 1 If installed, remove the front bezel.
- 2 Turn off the server modules using the operating system commands or the CMC.
- 3 Turn off the enclosure, including any attached peripherals, and disconnect the enclosure from its electrical outlet.
- 4 To reduce the chassis weight, remove the following (if required):
  - a hard drives
  - b server modules
  - c power supply units (PSUs)
- 5 If applicable, rotate the system feet inward and lay the system on its side on a flat stable surface, with the cover release latch side on top.
- 6 Open the system.
- 7 Remove the cooling shroud.
- 8 Remove the cooling fan assembly.
- 9 Remove the SAS cables and the backplane expander board. See [Removing The Backplane Expander Board](#).  
For the 3.5-inch hard drive chassis, remove the hard drives and the hard drive backplane. See [Removing The Hard-Drive Backplane](#).
- 10 To remove the optical drive blank, press the blue release tab at the back of the blank and push the blank out of the system.
- 11 Align the optical drive with the optical drive slot on the front of the enclosure.
- 12 Slide the optical drive into the slot until the latch snaps into place.
- 13 Connect the power and data cable to the back of the drive.
- 14 Route the power and data cable along the chassis base.

- 15 Connect the power and data cable to the connectors on the system board.
- 16 Reinstall the SAS cables and backplane expander board. See [Installing The Backplane Expander Board](#).  
For the 3.5-inch hard drive chassis, reinstall the hard drive backplane. See [Installing The Hard-Drive Backplane](#).
- 17 Install the cooling fan assembly.
- 18 Install the cooling shroud.
- 19 Close the system.
- 20 If applicable, place the system upright on a flat, stable surface and rotate the system feet outward.
- 21 If removed, reinstall the hard drives, server modules, and PSUs.
- 22 Reconnect the enclosure to its electrical outlet and turn the enclosure on, including any attached peripherals.
- 23 Turn on the server modules using the operating system commands or the CMC.
- 24 If applicable, install the front bezel.

## CMC cards

Your system supports two CMC cards.

## CMC card indicators



**Figure 54. CMC card indicators**

- |                    |                   |
|--------------------|-------------------|
| 1 status indicator | 2 power indicator |
|--------------------|-------------------|

The CMC card indicators provide the following information:

Indicator	Description
Power indicator	<b>Green</b> The CMC card is receiving power.
	<b>Off</b> The CMC card is not receiving power.



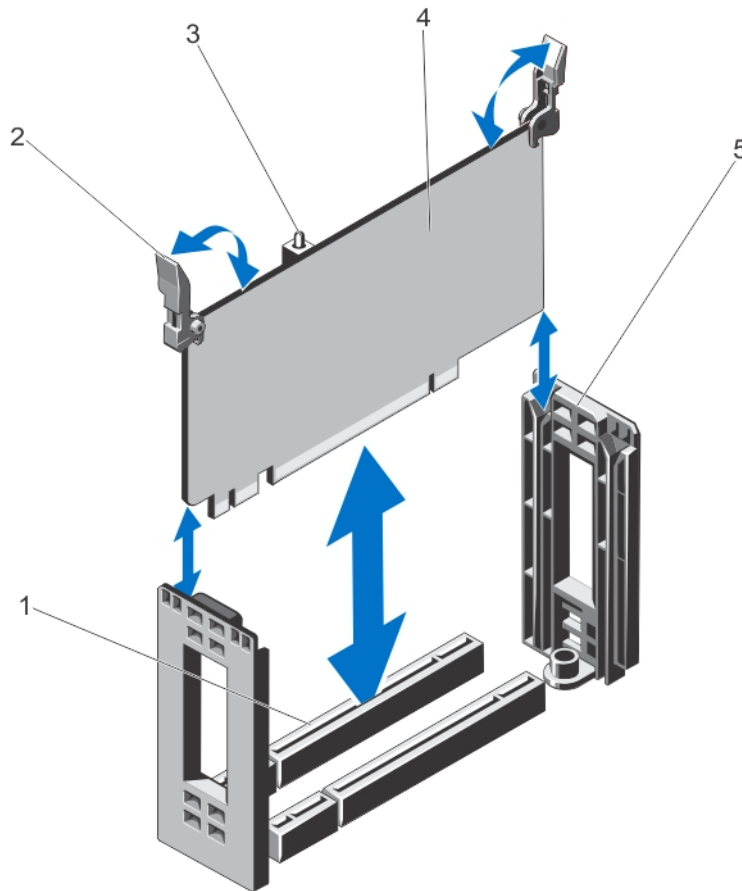
Indicator	Description	
Status indicator	Blue	The CMC card is active and operating normally.
	Amber	The CMC card is in fault condition.

**NOTE:** In a redundant (two-CMC) configuration, only the power indicator is enabled on the standby CMC.

## Removing a CMC card

**CAUTION:** Many repairs may only be done by a certified service technician. You should only perform troubleshooting and simple repairs as authorized in your product documentation, or as directed by the online or telephone service and support team. Damage due to servicing that is not authorized by Dell is not covered by your warranty. Read and follow the safety instructions that are shipped with your product.

- 1 Open the system.
- 2 Turn the two release tabs upward to disengage the CMC card from the CMC connector on the system board.
- 3 Holding the release tabs, lift the CMC card from the CMC connector and slide it out of the card support bracket.



**Figure 55. Removing and installing a CMC card**

- |   |                                    |   |                  |
|---|------------------------------------|---|------------------|
| 1 | CMC card connector on system board | 2 | release tabs (2) |
| 3 | CMC card indicators (2)            | 4 | CMC card         |

## Installing a CMC card

**⚠ CAUTION:** Many repairs may only be done by a certified service technician. You should only perform troubleshooting and simple repairs as authorized in your product documentation, or as directed by the online or telephone service and support team. Damage due to servicing that is not authorized by Dell is not covered by your warranty. Read and follow the safety instructions that are shipped with your product.

- 1 Align the CMC card with the card support bracket, and holding the release tabs, slide it down the bracket.
- 2 Lower the CMC card into the CMC connector on the system board.
- 3 Lock the CMC card into the CMC connector by rotating the release tabs downward, until firmly seated.
- 4 Close the system.

## PCIe cage

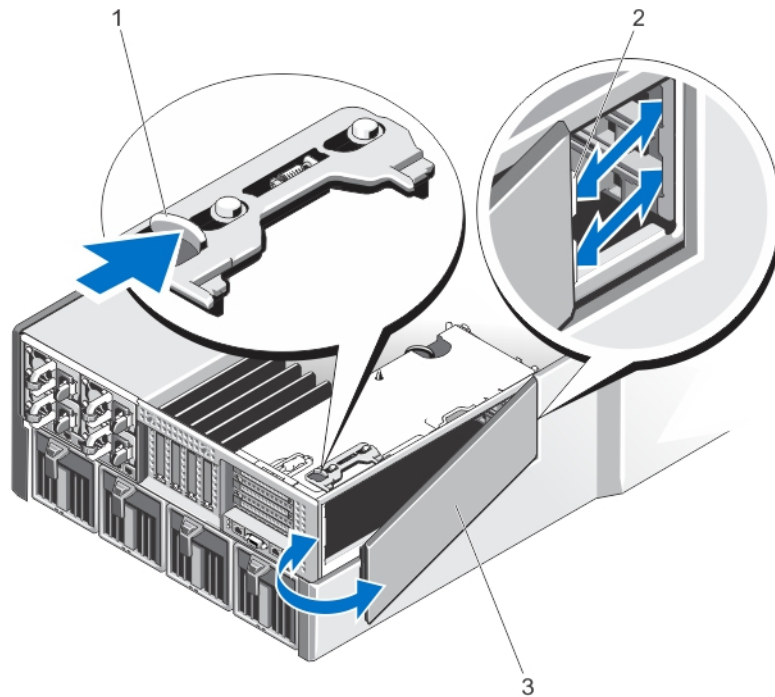
The PCIe cage consists of the following:

- Expansion card riser
- Full height expansion card divider unit
- Up to three full height expansion cards

## Removing the PCIe cage door

**⚠ CAUTION:** Many repairs may only be done by a certified service technician. You should only perform troubleshooting and simple repairs as authorized in your product documentation, or as directed by the online or telephone service and support team. Damage due to servicing that is not authorized by Dell is not covered by your warranty. Read and follow the safety instructions that are shipped with your product.

- 1 Open the system
- 2 Locate the PCIe cage door release tab on the PCIe cage.
- 3 Push the release tab toward the front of the system, and lift the cage door from the enclosure.
- 4 Angle the cage door and slide it toward the back of the system to disengage the tabs on the door from the chassis slots, and remove the door from the enclosure.



**Figure 56. Removing and installing the PCIe cage door**

- |   |  |
|---|--|
| <ul style="list-style-type: none"> <li>1 release tab</li> <li>3 PCIe cage door</li> </ul> | <ul style="list-style-type: none"> <li>2 tabs on the PCIe cage door (2)</li> </ul> |
|---|--|

## Installing the PCIe cage door

**CAUTION:** Many repairs may only be done by a certified service technician. You should only perform troubleshooting and simple repairs as authorized in your product documentation, or as directed by the online or telephone service and support team. Damage due to servicing that is not authorized by Dell is not covered by your warranty. Read and follow the safety instructions that are shipped with your product.

- 1 Align the tabs on the PCIe cage door with the slots on the chassis in an orientation as shown in the image.
- 2 Slide the cage door toward the front of the system until the tabs engage with the chassis slots.
- 3 Lower the other side of the PCIe cage door into the chassis, until it is firmly seated.
- 4 Close the system.

## Removing the PCIe cage

**CAUTION:** Many repairs may only be done by a certified service technician. You should only perform troubleshooting and simple repairs as authorized in your product documentation, or as directed by the online or telephone service and support team. Damage due to servicing that is not authorized by Dell is not covered by your warranty. Read and follow the safety instructions that are shipped with your product.

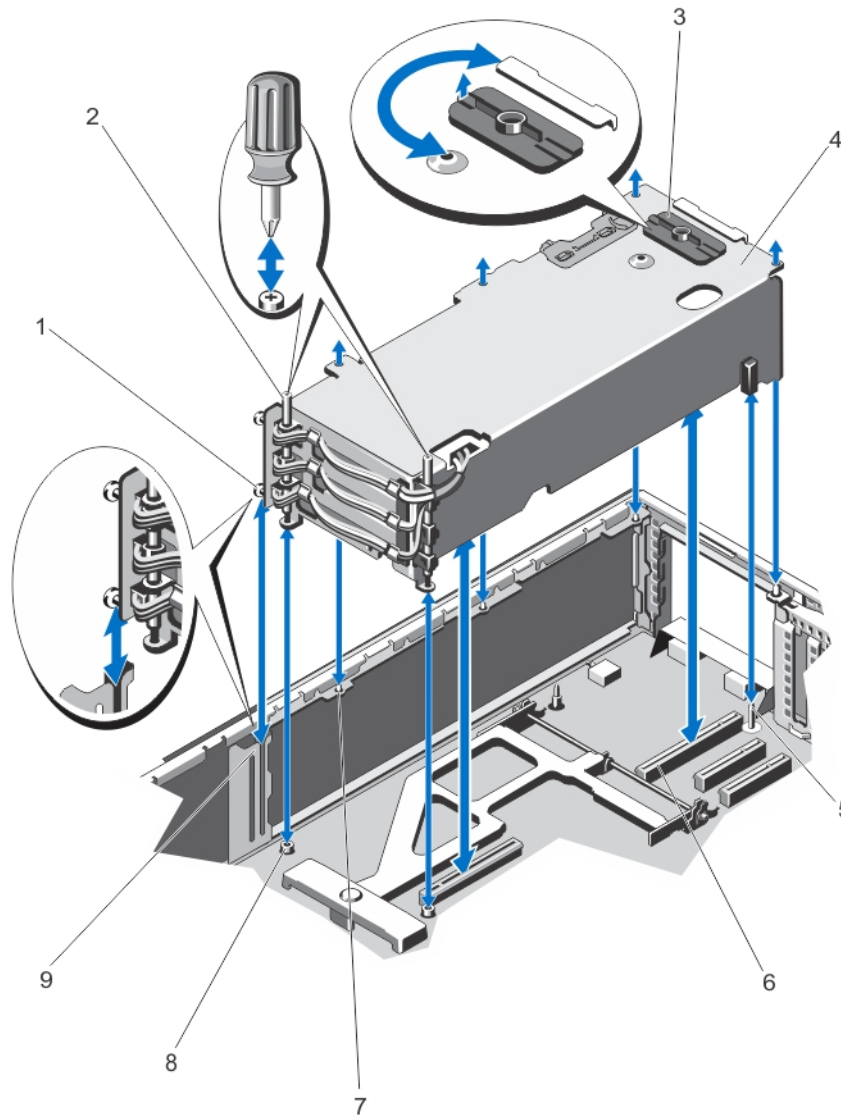
**NOTE:** If the system is in the rack mode, the rack door may prevent the removal and installation of the PCIe cage.

- 1 If installed, remove the front bezel.
- 2 Turn off the server modules using the operating system commands or the CMC.
- 3 Turn off the enclosure, including any attached peripherals, and disconnect the enclosure from the electrical outlet.

- 4 To reduce the chassis weight, remove the following (if required):
  - a hard drives
  - b server modules
  - c power supply units
- 5 If applicable, rotate the system feet inward and lay the system on its side on a flat stable surface, with the cover release latch side on top.
- 6 Open the system.
- 7 Open the PCIe cage door.
- 8 Remove the cooling shroud.
- 9 Remove the cooling fan assembly.

 **NOTE: It is recommended that you remove the CMC cards before removing the PCIe cage.**

- 10 Rotate the release latch to open position to unlock the PCIe cage from the chassis.
- 11 Loosen the two screws securing the PCIe cage to the chassis, until they disengage from the chassis.
- 12 Holding the PCIe cage by the slots, lift the cage up and away from the chassis.



**Figure 57. Removing and installing the PCIe cage**

- |   |                               |   |                                     |
|---|-------------------------------|---|-------------------------------------|
| 1 | metal standoffs (2)           | 2 | screws (2)                          |
| 3 | release latch                 | 4 | PCIe cage                           |
| 5 | guide pin                     | 6 | expansion card riser connectors (2) |
| 7 | metal tabs on the chassis (4) | 8 | screw holes (2)                     |
| 9 | bracket on chassis side       |   |                                     |

## Installing the PCIe cage

**⚠ CAUTION:** Many repairs may only be done by a certified service technician. You should only perform troubleshooting and simple repairs as authorized in your product documentation, or as directed by the online or telephone service and support team. Damage due to servicing that is not authorized by Dell is not covered by your warranty. Read and follow the safety instructions that are shipped with your product.

- 1 Align the following:
  - a the two metal standoffs on one side of the PCIe cage, toward the PCIe cage door, with the bracket on the chassis side.

- b the expansion card riser connectors with the connectors on the system board.
  - c the slot on the expansion card riser with the guide pin on the system board.
- 2 Slide the PCIe cage into the chassis, until firmly seated.  
When firmly seated, the slots on the PCIe cage align with the metal tabs on the chassis.
  - 3 Tighten the two screws to secure the PCIe cage to the chassis.
  - 4 Rotate the release latch to lock position, to secure the PCIe cage to the chassis.
  - 5 Reinstall the expansion cards, if applicable, or the filler brackets.
  - 6 Reinstall the cooling fan assembly.
  - 7 Reinstall the cooling shroud.
  - 8 Close the PCIe cage door.
  - 9 Close the system.
  - 10 If applicable, place the system upright on a flat, stable surface and rotate the system feet outward.
  - 11 If removed, reinstall the hard drives, server modules, and power supply units.
  - 12 Reconnect the enclosure to its electrical outlet and turn the enclosure on, including any attached peripherals.
  - 13 Turn on the server modules using the operating system commands or the CMC.
  - 14 If applicable, install the front bezel.

## Expansion cards

### Expansion card installation guidelines

The following table describes the expansion card slots in the VRTX enclosure:

**Table 4. Expansion card slots**

Location	PCIe Slot	Fabric	Height	Length	Link Width
Riser	1	C	Standard Height	Full Length	x8
Riser	2	C	Standard Height	Full Length	x8
Riser	3	B	Standard Height	Full Length	x8
System board	4	C	Low Profile	Half Length	x8
System board	5	C	Low Profile	Half Length	x8
System board	6	B	Low Profile	Half Length	x8
System board	7	B	Low Profile	Half Length	x8
System board	8	B	Low Profile	Half Length	x8

The following table provides guidelines for installing expansion cards to ensure proper cooling and mechanical fit. The expansion cards with the highest priority must be installed first using the slot priority indicated. All other expansion cards must be installed in card priority and slot priority order.

**Table 5. Expansion card installation order**

Card Priority	Card Type	Form Factor	Slot Priority	Maximum Allowed
1	Shared PERC 8 Internal	N/A	INT_STORAGE_1, INT_STORAGE_2	2
2	Shared PERC 8 External	Low profile	6, 5	2
3	External SAS RAID	Standard height	3, 2	2
		Low profile	6, 5	2
4	GPU	Standard height	2, 3, 1	3
5	10 Gb NICs	Standard height	2, 3, 1	3
		Low profile	6, 5, 7, 4, 8	5
6	FC HBA	Standard height	2, 3, 1	3
		Low profile	6, 5, 7, 4, 8	5
7	1Gb NICs	Standard height	2, 3, 1	3
		Low profile	6, 5, 7, 4, 8	5
8	SAS Non-RAID	Standard height	2, 3, 1	2
		Low profile	6, 5, 7, 4, 8	2

## Expansion card operational power status

The following table provides information on the operational power status of the expansion cards when:

- the expansion card is installed in a PCIe slot mapped to a server module
- the system cover is installed

**Table 6. Expansion card operational power status**

Chassis Status	Server Module Status	Expansion Card Status
Off	Off	Off
Standby	Off	Off
On	Off	On for 5 minutes and then Off.
		<b>i</b> <b>NOTE: The expansion card status turns to Off immediately if the system cover is removed.</b>
On	On	On

The following table provides information on the operational power status of an expansion card when:

- the expansion card is replaced in the PCIe slot
- the system cover is removed

**Table 7. Expansion card operational power status**

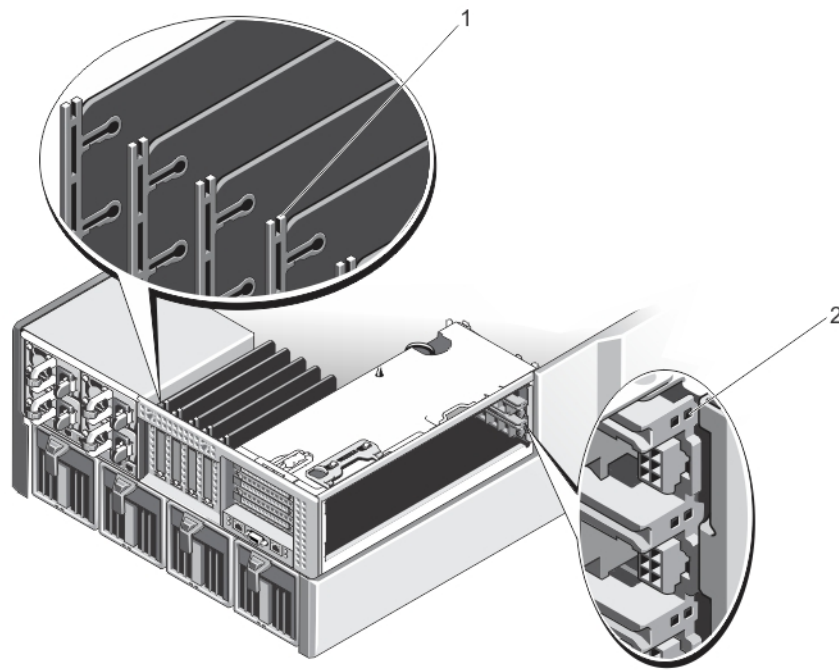
Chassis Status	Server Module Status	Expansion Card Status
On	Off	Off
On	On	Off

**NOTE:** The system cover must be installed for the new expansion card to turn on.

**NOTE:** To verify if a PCIe slot is powered on, see [PCIe Slot Indicators](#).

## PCIe slot indicators

The expansion card slots are warm-plug. A PCIe card has to be prepared for removal from a system that is turned on, using the CMC. The PCIe slot indicators show that a PCIe card is ready for removal.



**Figure 58. PCIe slot indicators**

1 PCIe slot indicators for low-profile expansion cards

2 PCIe slot indicators for full-height expansion cards

The PCIe slot indicators provide the following information:

Indicator	Description	
Slot power indicator	<b>Steady Green</b>	The slot is receiving power.
	<b>Blinking Green</b>	Warm-plug operation is in progress and insertion or removal of the adapter is not allowed.
	<b>Off</b>	Power supply to the slot is off, and the expansion card can be removed.



Indicator	Description	
Slot attention indicator	Steady Amber	The adapter or slot is in a fault condition.
	Blinking Amber	The indicator blinks for 15 seconds after the slot identify command.
	Off	The slot is operating normally, or no expansion card is installed in the slot.

## Removing a low profile expansion card

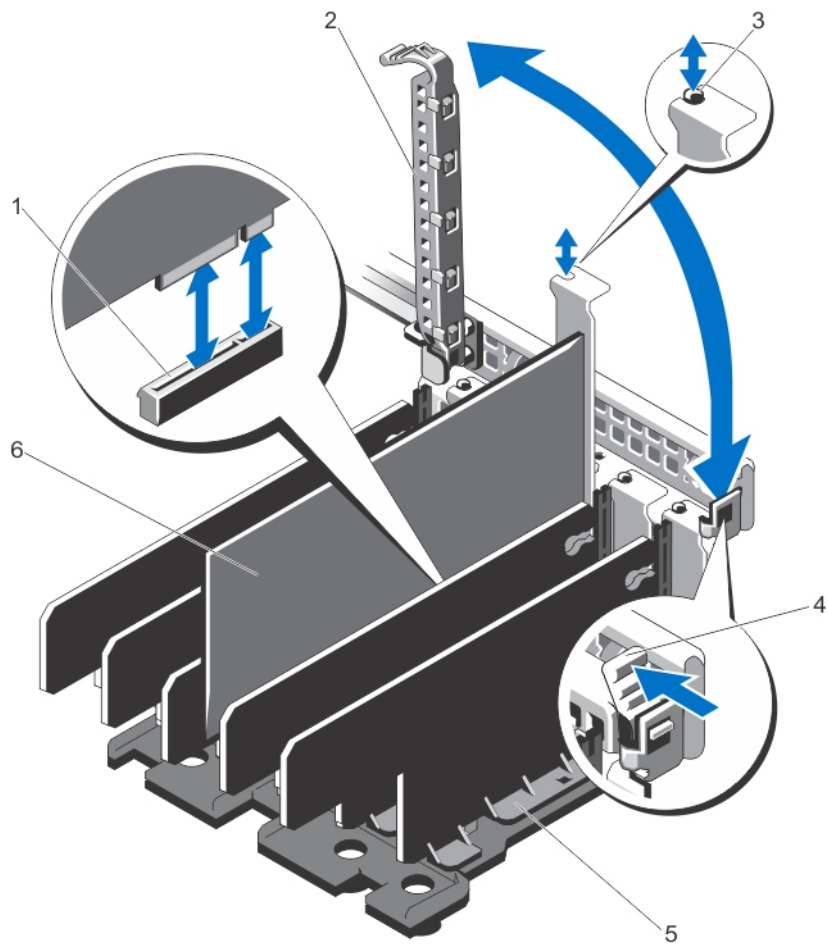
**CAUTION:** Many repairs may only be done by a certified service technician. You should only perform troubleshooting and simple repairs as authorized in your product documentation, or as directed by the online or telephone service and support team. Damage due to servicing that is not authorized by Dell is not covered by your warranty. Read and follow the safety instructions that are shipped with your product.

**NOTE:** The system must be closed to initiate expansion card discovery in the CMC.

- 1 Turn off the server module to which the expansion card is assigned, using the operating system commands or the CMC.
- 2 Open the system.
- 3 Disconnect any cables connected to the expansion card.
- 4 Press the release tab of the expansion card latch to lift the latch out of the chassis slot.
- 5 Grasp the expansion card by its edges, and remove it from the expansion card connector.
- 6 If you are removing the card permanently, install a metal filler bracket over the empty expansion slot opening and close the expansion card latch.

**NOTE:** You must install a filler bracket over an empty expansion card slot to maintain Federal Communications Commission (FCC) certification of the system. The brackets also keep dust and dirt out of the system and aid in proper cooling and airflow inside the system. The filler bracket is necessary to maintain proper thermal conditions.

- 7 Close the system.
- 8 Turn on the server module using the operating system commands or the CMC.



**Figure 59. Removing and installing a low profile expansion card**

- |   |                             |   |                                  |
|---|-----------------------------|---|----------------------------------|
| 1 | expansion card connector    | 2 | expansion card latch             |
| 3 | metal standoff              | 4 | expansion card latch release tab |
| 5 | expansion card divider unit | 6 | low profile expansion card       |

## Installing a low profile expansion card

**CAUTION:** Many repairs may only be done by a certified service technician. You should only perform troubleshooting and simple repairs as authorized in your product documentation, or as directed by the online or telephone service and support team. Damage due to servicing that is not authorized by Dell is not covered by your warranty. Read and follow the safety instructions that are shipped with your product.

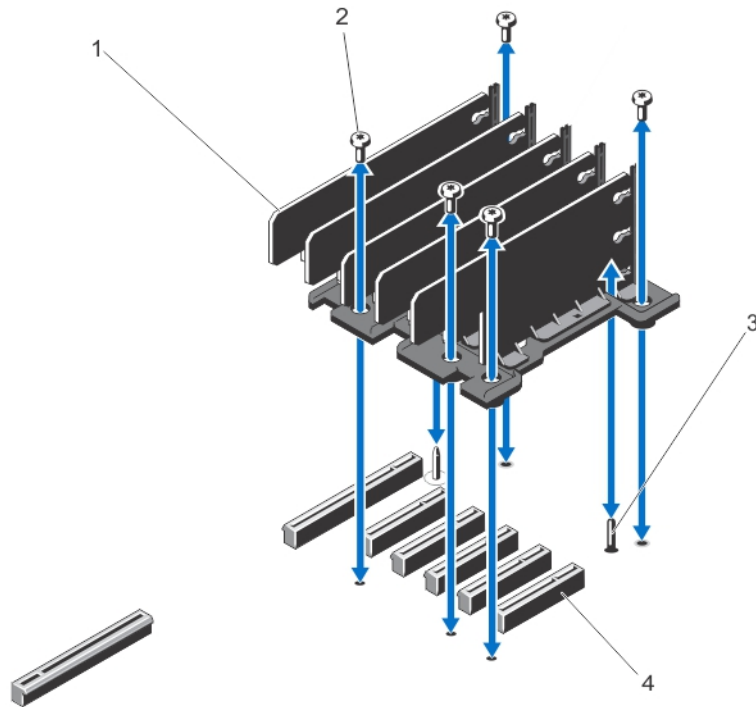
1. Unpack the expansion card and prepare it for installation.  
For instructions, see the documentation accompanying the card.
2. Turn off the server module to which the expansion card is assigned, using the operating system commands or the CMC.
3. Open the system.
4. Lift the expansion card latch out of the chassis slot.
5. Remove the filler bracket.
6. Holding the card by its edges, position the card so that the card-edge connector aligns with the expansion card connector.
7. Align the expansion card bracket with the metal standoff on the chassis.
8. Insert the card-edge connector firmly into the expansion card connector until the card is fully seated.

- 9 Close the expansion card latch.
- 10 If applicable, connect cables to the expansion card.
- 11 Close the system.
- 12 Map the expansion card to the server module using the CMC (if not already mapped).
- 13 Turn on the server module using the operating system commands or the CMC.
- 14 Install any device drivers required for the card as described in the documentation for the card.

## Removing the low profile expansion card divider unit

**⚠ CAUTION:** Many repairs may only be done by a certified service technician. You should only perform troubleshooting and simple repairs as authorized in your product documentation, or as directed by the online or telephone service and support team. Damage due to servicing that is not authorized by Dell is not covered by your warranty. Read and follow the safety instructions that are shipped with your product.

- 1 If installed, remove the front bezel.
- 2 Turn off the server modules using the operating system commands or the CMC.
- 3 Turn off the enclosure, including any attached peripherals, and disconnect the enclosure from the electrical outlet and peripherals.
- 4 To reduce the chassis weight, remove the following (if required):
  - a hard drives
  - b server modules
  - c power supply units
- 5 If applicable, rotate the system feet inward and lay the system on its side on a flat stable surface, with the cover release latch side on top.
- 6 Open the system.
- 7 If applicable, remove the low profile expansion cards.
- 8 Remove the five screws securing the expansion card divider unit to the chassis.
- 9 Holding it by its sides, lift the divider unit up and away from the chassis.



**Figure 60. Removing and installing the low profile expansion card divider unit**

- |   |                        |   |   |
|---|------------------------|---|---|
| 1 | expansion card divider | 2 | screws (5)                                    |
| 3 | guide pin              | 4 | expansion card connectors on system board (5) |

## Installing the low profile expansion card divider unit

**CAUTION:** Many repairs may only be done by a certified service technician. You should only perform troubleshooting and simple repairs as authorized in your product documentation, or as directed by the online or telephone service and support team. Damage due to servicing that is not authorized by Dell is not covered by your warranty. Read and follow the safety instructions that are shipped with your product.

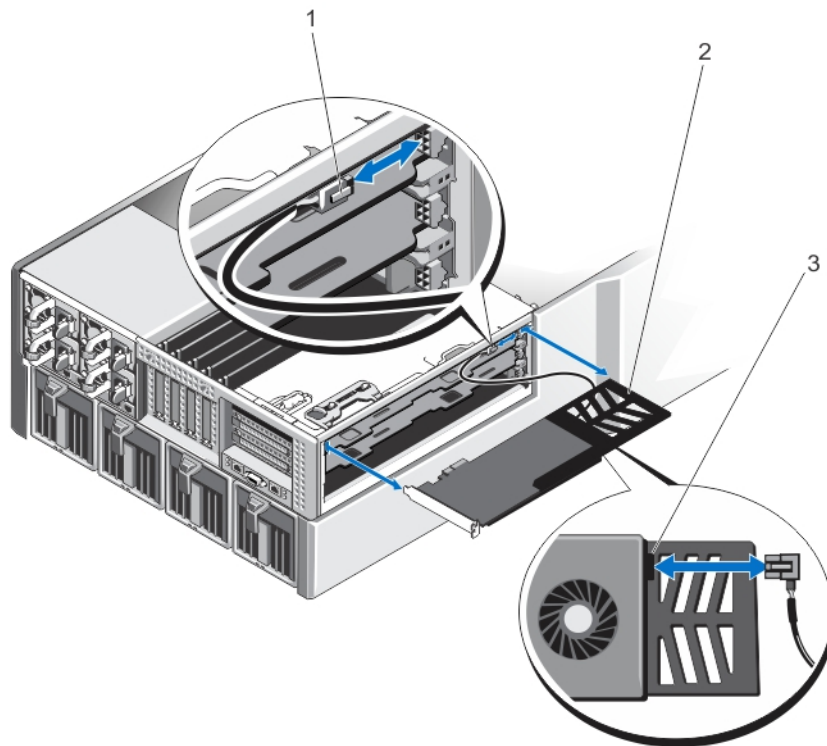
- 1 Align the expansion card divider unit with the guide pin on the system board.
- 2 Lower the divider unit into the chassis.  
When properly seated, the screw holes on the divider unit align with the screw holes on the chassis.
- 3 Install the screws to secure the divider unit to the chassis.
- 4 If applicable, reinstall the expansion cards.
- 5 Close the system.
- 6 If applicable, place the system upright on a flat, stable surface and rotate the system feet outward.
- 7 If removed, reinstall the hard drives, server modules, and power supply units.
- 8 Reconnect the enclosure to its electrical outlet and turn the enclosure on, including any attached peripherals.
- 9 Turn on the server modules using the operating system commands or the CMC.
- 10 If applicable, install the front bezel.

# Removing a full height expansion card

**CAUTION:** Many repairs may only be done by a certified service technician. You should only perform troubleshooting and simple repairs as authorized in your product documentation, or as directed by the online or telephone service and support team. Damage due to servicing that is not authorized by Dell is not covered by your warranty. Read and follow the safety instructions that are shipped with your product.

**NOTE:** The system cover must be closed to initiate expansion card discovery in the CMC.

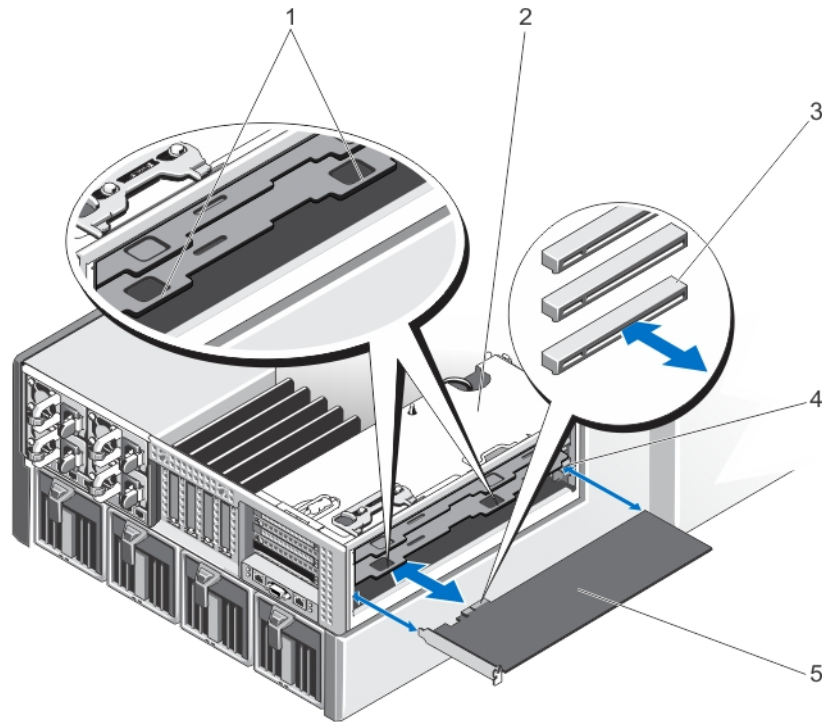
- 1 Turn off the server module to which the expansion card is assigned, using the operating system commands or the CMC.
- 2 Open the system.
- 3 Open the PCIe cage door.
- 4 If applicable, disconnect the power cable on the card from the power cable connector on the PCIe cage.



**Figure 61. Removing and installing the power cable to the expansion card**

- 1 power cable connector to PCIe cage
  - 2 expansion card bracket
  - 3 power cable connector on expansion card
- 5 Pull the tabs on the expansion card divider to release the expansion card.
  - 6 Remove the expansion card from the expansion card connector on the riser, and slide it out of the PCIe cage.
  - 7 If you are removing the card permanently, install a metal filler bracket over the empty expansion slot opening and close the expansion card latch.
- NOTE:** You must install a filler bracket over an empty expansion card slot to maintain Federal Communications Commission (FCC) certification of the system. The brackets also keep dust and dirt out of the system and aid in proper cooling and airflow inside the system. The filler bracket is necessary to maintain proper thermal conditions.
- 8 Close the PCIe cage door.
  - 9 Close the system.

- 10 Turn on the server module using the operating system commands or the CMC.



**Figure 62. Removing and installing a full-height expansion card**

- |   |  |   |                                |
|---|--|---|--------------------------------|
| 1 | tabs on expansion card divider (2)         | 2 | PCIe cage                      |
| 3 | expansion card connectors on the riser (3) | 4 | expansion card support bracket |
| 5 | expansion card                             |   |                                |

## Installing a full height expansion card

**⚠ CAUTION:** Many repairs may only be done by a certified service technician. You should only perform troubleshooting and simple repairs as authorized in your product documentation, or as directed by the online or telephone service and support team. Damage due to servicing that is not authorized by Dell is not covered by your warranty. Read and follow the safety instructions that are shipped with your product.

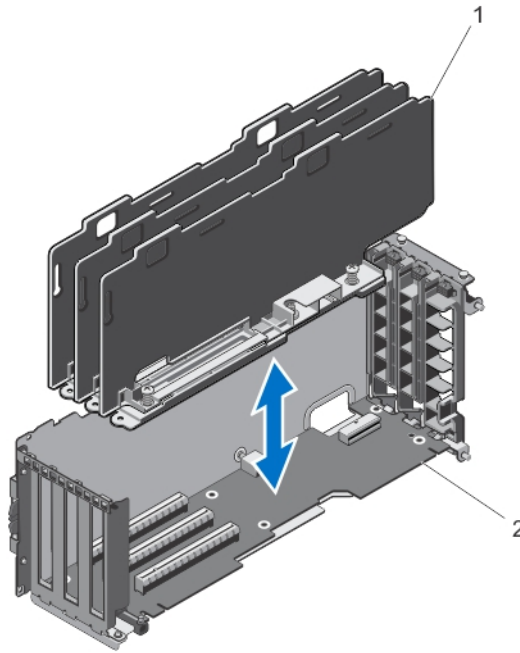
- 1 Unpack the expansion card and prepare it for installation.  
For instructions, see the documentation accompanying the card.
- 2 Turn off the server module to which the expansion card is assigned, using the operating system commands or the CMC.
- 3 Open the system.
- 4 Open the PCIe cage door.
- 5 Remove the filler bracket.
- 6 Holding the card by its edges, position the card so that the card aligns with the support bracket on the PCIe cage, and the card-edge connector aligns with the expansion card connector on the expansion card riser.
- 7 Slide the expansion card into the PCIe cage and insert the card-edge connector firmly into the expansion card connector on the riser, until the card is fully seated.
- 8 If applicable, connect the power cable on the card to the power cable connector on the PCIe cage.
- 9 Close the PCIe cage door.
- 10 Close the system.
- 11 Map the expansion card to the server module using the CMC (if not already mapped).

- 12 Turn on the server module using the operating system commands or the CMC.
- 13 Install any device drivers required for the card as described in the documentation for the card.

## Removing the full-height expansion card divider unit

**⚠ CAUTION:** Many repairs may only be done by a certified service technician. You should only perform troubleshooting and simple repairs as authorized in your product documentation, or as directed by the online or telephone service and support team. Damage due to servicing that is not authorized by Dell is not covered by your warranty. Read and follow the safety instructions that are shipped with your product.

- 1 If installed, remove the front bezel.
- 2 Turn off the server modules using the operating system commands or the CMC.
- 3 Turn off the enclosure, including any attached peripherals, and disconnect the enclosure from the electrical outlet and peripherals.
- 4 To reduce the chassis weight, remove the following (if required):
  - a hard drives
  - b server modules
  - c power supply units
- 5 If applicable, rotate the system feet inward and lay the system on its side on a flat stable surface, with the cover release latch side on top.
- 6 Open the system.
- 7 Open the PCIe cage door.
- 8 Remove the cooling shroud.
- 9 Remove the cooling fan assembly.
- 10 Remove the PCIe cage.
- 11 If applicable, remove any expansion card installed on the expansion card riser.
- 12 Remove the screws securing the divider unit to the riser and PCIe cage.
- 13 Holding it by its sides, lift the divider unit up and away from the PCIe cage.



**Figure 63. Removing and installing the full-height expansion card divider unit**

1 expansion card divider unit

2 expansion card riser

## Installing the full height expansion card divider unit

**⚠ CAUTION:** Many repairs may only be done by a certified service technician. You should only perform troubleshooting and simple repairs as authorized in your product documentation, or as directed by the online or telephone service and support team. Damage due to servicing that is not authorized by Dell is not covered by your warranty. Read and follow the safety instructions that are shipped with your product.

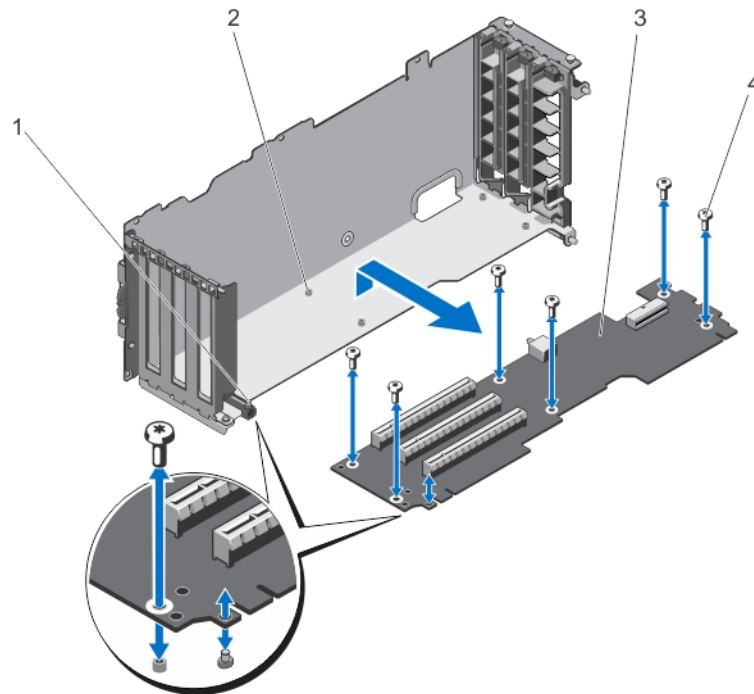
- 1 Align the screw holes on the expansion card divider unit with the screw holes on the expansion card riser.
- 2 Lower the divider unit into the PCIe cage and attach the screws to secure the unit to the riser and PCIe cage.
- 3 If applicable, reinstall the expansion cards.
- 4 Reinstall the PCIe cage.
- 5 Reinstall the cooling fan assembly.
- 6 Reinstall the cooling shroud.
- 7 Close the PCIe cage door.
- 8 Close the system.
- 9 If applicable, place the system upright on a flat, stable surface and rotate the system feet outward.
- 10 If removed, reinstall the hard drives, server modules, and power supply units.
- 11 Reconnect the enclosure to its electrical outlet and turn the enclosure on, including any attached peripherals.
- 12 Turn on the server modules using the operating system commands or the CMC.
- 13 If applicable, install the front bezel.



# Removing the expansion card riser

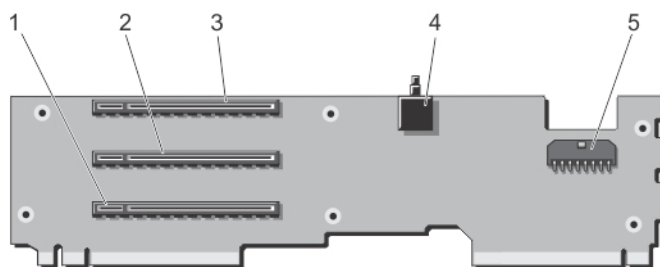
**CAUTION:** Many repairs may only be done by a certified service technician. You should only perform troubleshooting and simple repairs as authorized in your product documentation, or as directed by the online or telephone service and support team. Damage due to servicing that is not authorized by Dell is not covered by your warranty. Read and follow the safety instructions that are shipped with your product.

- 1 If installed, remove the front bezel.
- 2 Turn off the server modules using the operating system commands or the CMC.
- 3 Turn off the enclosure, including any attached peripherals, and disconnect the enclosure from the electrical outlet and peripherals.
- 4 If applicable, rotate the system feet inward and lay the system on its side on a flat stable surface, with the cover release latch side on top.
- 5 Open the system.
- 6 Open the PCIe cage door.
- 7 Remove the cooling shroud.
- 8 Remove the cooling fan assembly.
- 9 Remove the PCIe cage.
- 10 If applicable, remove any expansion card installed on the riser.
- 11 Remove the full-height expansion card divider unit.
- 12 Disconnect the power cable from the expansion card riser.
- 13 Remove the screws securing the expansion card riser to the PCIe cage.
- 14 Slide the expansion card riser out of the PCIe cage.



**Figure 64. Removing and installing the expansion card riser**

- |   |                      |   |                 |
|---|----------------------|---|-----------------|
| 1 | PCIe cage            | 2 | screw holes (6) |
| 3 | expansion card riser | 4 | screws (6)      |



**Figure 65. Expansion card riser connectors**

- |   |                                  |   |                                  |
|---|----------------------------------|---|----------------------------------|
| 1 | expansion card connector (SLOT3) | 2 | expansion card connector (SLOT2) |
| 3 | expansion card connector (SLOT1) | 4 | chassis intrusion switch         |
| 5 | power cable connector            |   |                                  |

## Installing the expansion card riser

**CAUTION:** Many repairs may only be done by a certified service technician. You should only perform troubleshooting and simple repairs as authorized in your product documentation, or as directed by the online or telephone service and support team. Damage due to servicing that is not authorized by Dell is not covered by your warranty. Read and follow the safety instructions that are shipped with your product.

- 1 Align the expansion card riser with the PCIe cage and slide the riser into the cage, until properly seated. When properly aligned, the chassis intrusion switch on the riser aligns with the slot on the PCIe cage.
- 2 Attach the screws to secure the expansion card to the PCIe cage.
- 3 Reconnect the power cable.
- 4 Reinstall the full-height expansion card divider unit.
- 5 If applicable, reinstall the expansion card(s) into the expansion card riser.
- 6 Reinstall the PCIe cage.
- 7 Reinstall the cooling fan assembly.
- 8 Reinstall the cooling shroud.
- 9 Close the PCIe cage door.
- 10 Close the system.
- 11 If applicable, place the system upright on a flat, stable surface and rotate the system feet outward.
- 12 Reconnect the enclosure to its electrical outlet and turn the enclosure on, including any attached peripherals.
- 13 Turn on the server modules using the operating system commands or the CMC.
- 14 If applicable, install the front bezel.

## Double-wide GPGPU card (optional)

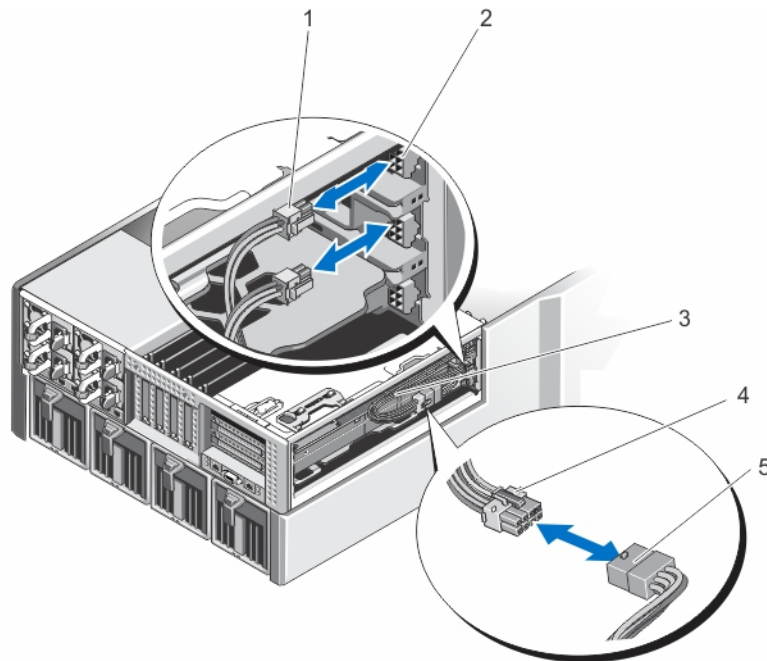
The optional double-wide General Purpose Computation on Graphics Processors (GPGPU) card is shipped with a double-wide PCIe cage. You must install the double-wide GPGPU card in the double-wide PCIe cage.

**NOTE:** The procedure for removing and installing the double-wide PCIe cage is identical to removing and installing the single-wide PCIe cage in the enclosure.

# Removing a double-wide GPGPU card

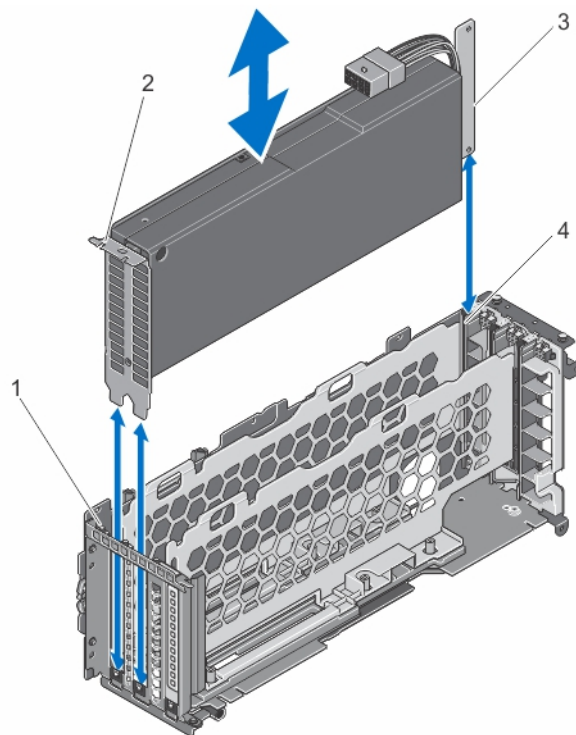
**CAUTION:** Many repairs may only be done by a certified service technician. You should only perform troubleshooting and simple repairs as authorized in your product documentation, or as directed by the online or telephone service and support team. Damage due to servicing that is not authorized by Dell is not covered by your warranty. Read and follow the safety instructions that are shipped with your product.

- 1 If installed, remove the front bezel.
- 2 Turn off the server modules using the operating system commands or the CMC.
- 3 Turn off the enclosure, including any attached peripherals, and disconnect the enclosure from the electrical outlet.
- 4 To reduce the chassis weight, remove the following (if required):
  - a hard drives
  - b server modules
  - c power supply units (PSUs)
- 5 If applicable, rotate the system feet inward and lay the system on its side on a flat stable surface, with the cover release latch side on top.
- 6 Open the system.
- 7 Open the PCIe cage door.
- 8 Disconnect the 6-pin connectors of the auxiliary power cable from the power cable connectors on the double-wide PCIe cage.
- 9 Disconnect the 8-pin connector of the auxiliary power cable from the power cable of the double-wide GPGPU card.



**Figure 66. Removing and installing the auxiliary power cable to the power cable connectors**

- |   |  |   |   |
|---|--|---|---|
| 1 | 6-pin connector of the auxiliary power cable (2) | 2 | power cable connectors on the double-wide PCIe cage |
| 3 | auxiliary power cable                            | 4 | 8-pin connector of the auxiliary power cable        |
| 5 | power cable of the double-wide GPGPU card        |   |   |
- 10 Remove the double-wide PCIe cage. See [Removing The PCIe Cage](#).
  - 11 Remove the double-wide GPGPU card from the expansion card connector on the riser, and slide it out of the double-wide PCIe cage.



**Figure 67. Removing and installing a double-wide GPGPU card**

- |   |                                  |   |                                |
|---|----------------------------------|---|--------------------------------|
| 1 | tab on the double-wide PCIe cage | 2 | double-wide GPGPU card bracket |
| 3 | double-wide GPGPU card           | 4 | double-wide PCIe cage          |

12 Replace the double-wide GPGPU card and install the double-wide PCIe cage, if applicable. See [Installing The PCIe Cage](#).

**NOTE:** If you are not installing a double-wide GPGPU card, install the single-wide PCIe cage in the enclosure. See [Installing The PCIe Cage](#).

- 13 If applicable, install the expansion card(s). See [Installing A Full Height Expansion Card](#).
- 14 Close the PCIe cage door.
- 15 Close the system.
- 16 If applicable, place the system upright on a flat, stable surface and rotate the system feet outward.
- 17 If removed, reinstall the hard drives, server modules, and PSUs.
- 18 Reconnect the enclosure to its electrical outlet and turn the enclosure on, including any attached peripherals.
- 19 Turn on the server modules using the operating system commands or the CMC.
- 20 If applicable, install the front bezel.

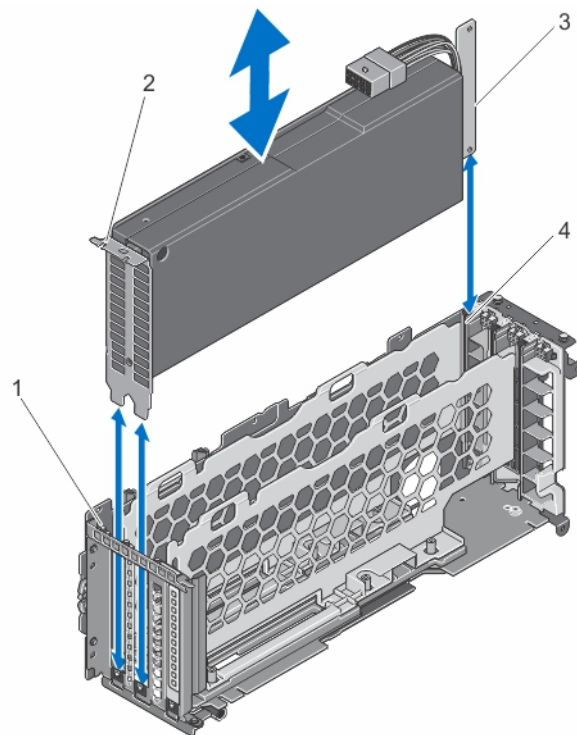
## Installing an optional double-wide GPGPU card

**CAUTION:** Many repairs may only be done by a certified service technician. You should only perform troubleshooting and simple repairs as authorized in your product documentation, or as directed by the online or telephone service and support team. Damage due to servicing that is not authorized by Dell is not covered by your warranty. Read and follow the safety instructions that are shipped with your product.

- 1 If installed, remove the front bezel.
- 2 Turn off the server modules using the operating system commands or the CMC.
- 3 Turn off the enclosure, including any attached peripherals, and disconnect the enclosure from the electrical outlet.
- 4 To reduce the chassis weight, remove the following (if required):

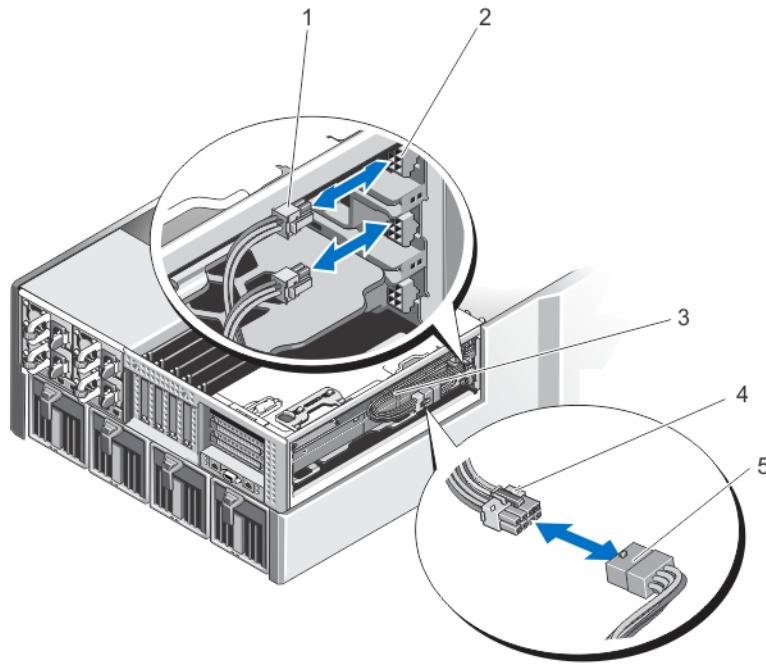
- a hard drives
  - b server modules
  - c power supplies
- 5 If applicable, rotate the system feet inward and lay the system on its side on a flat stable surface, with the cover release latch side on top.
  - 6 Open the system.
  - 7 Open the PCIe cage door.
  - 8 Remove the single-wide PCIe cage. See [Removing The PCIe Cage](#).
  - 9 Holding the double-wide GPGPU card by its edges, position the card so that the card bracket aligns with the tab on the double-wide PCIe cage.
  - 10 Align the double-wide GPGPU card-edge connector with the expansion card connector on the expansion card riser in the double wide PCIe cage.
  - 11 Lower the double-wide GPGPU card into the double-wide PCIe cage and insert the card-edge connector firmly into the expansion card connector on the riser, until the card is fully seated.

The double-wide GPGPU card bracket aligns with the tab on the double-wide PCIe cage.



**Figure 68. Installing the double-wide GPGPU card into the double-wide PCIe cage**

- |   |                                  |   |                                |
|---|----------------------------------|---|--------------------------------|
| 1 | tab on the double-wide PCIe cage | 2 | double-wide GPGPU card bracket |
| 3 | double-wide GPGPU card           | 4 | double-wide PCIe cage          |
- 12 Install the double-wide PCIe cage. See [Installing The PCIe Cage](#).
  - 13 Route the power cable from the double-wide GPGPU card into the double-wide PCIe cage.
  - 14 Connect the 8-pin connector on one end of the auxiliary power cable to the power cable connector of the double-wide GPGPU card.
  - 15 Connect the two 6-pin connectors on the other end of the auxiliary power cable to the power cable connectors on the double-wide PCIe cage.



**Figure 69. Installing the auxiliary power cable to the power cable connectors**

- |   |  |   |   |
|---|--|---|---|
| 1 | 6-pin connector of the auxiliary power cable (2) | 2 | power cable connectors on the double-wide PCIe cage |
| 3 | auxiliary power cable                            | 4 | 8-pin connector of the auxiliary power cable        |
| 5 | power cable of the double-wide GPGPU card        |   |   |

16 Close the PCIe cage door.

**NOTE:** Route the auxiliary power cables properly inside the double-wide PCIe cage to prevent them from being pinched or crimped.

17 Close the system.

18 If applicable, place the system upright on a flat, stable surface and rotate the system feet outward.

19 If removed, reinstall the hard drives, server modules, and power supplies.

20 Reconnect the enclosure to its electrical outlet and turn the enclosure on, including any attached peripherals.

21 Turn on the server modules using the operating system commands or the CMC.

22 If applicable, install the front bezel.

23 Map the double-wide GPGPU card to the server module using the CMC (if not already mapped).

## Integrated storage controller cards

Your system includes two dedicated expansion card slots on the system board for up to two integrated controller cards that provide the integrated storage subsystem for the internal hard drives in your system.

The storage controllers support SAS hard drives and also enable you to set up the hard drives in RAID configurations as supported by the version of the controllers included with your system.

**NOTE:** For information on setting up and configuring the storage controller cards, see the *Dell Shared PowerEdge RAID Controller (PERC) 8 For Dell PowerEdge VRTX Systems User's Guide* at [Dell.com/poweredgemanuals](http://Dell.com/poweredgemanuals).

## Storage controller operational power status

The following table provides information on the operational power status of the integrated storage controller card when:

- the storage controller slot is mapped to multiple server modules
- the system cover is installed

**Table 8. Storage controller operational power status**

Chassis Status	Server Module Status (All Server Modules)	Storage Controller Status
Off	Off	Off
Standby	Off	Off
On	Off or On	<ul style="list-style-type: none"> <li>· On — The status of the integrated storage controller card installed in storage controller slot 1, labelled as <b>INT_STORAGE_1</b> on the system board.</li> <li>· Off — The status of the integrated storage controller card slot 2, labelled as <b>INT_STORAGE_2</b> on the system board, in a single storage controller configuration.</li> </ul>

The following table provides information on the operational power status of a storage controller when:

- the storage controller card is replaced in the storage controller slot
- the system cover is removed

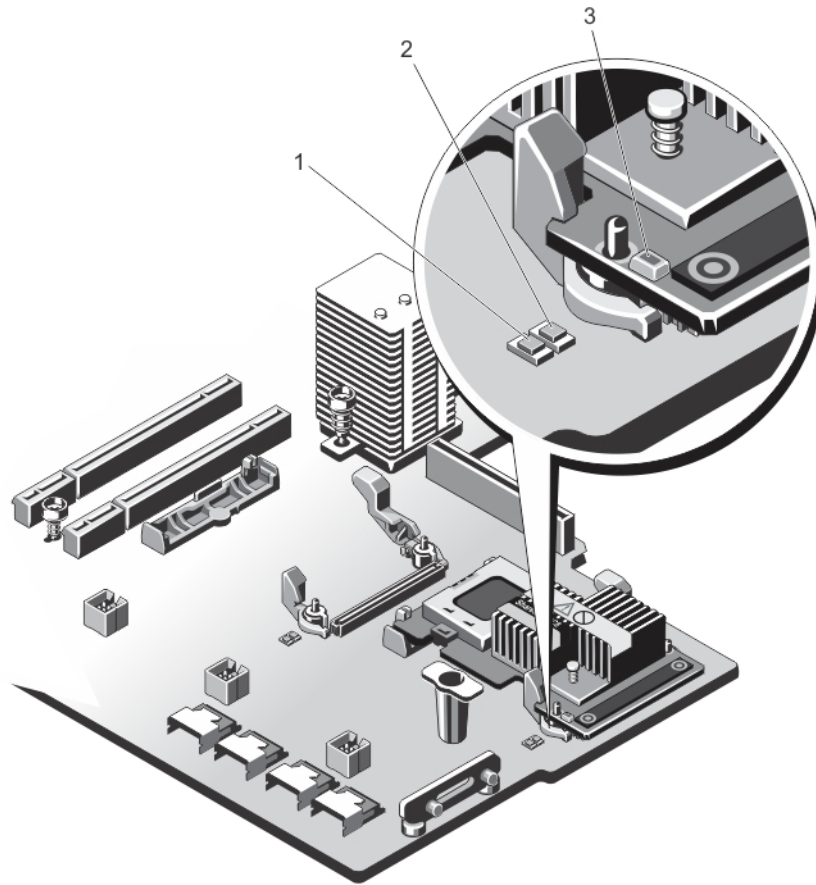
**Table 9. Storage controller operational power status**

Chassis Status	Server Module Status (All Server Modules)	Storage Controller Status
On	Off	Off
On	On	Off

**i** | **NOTE:** The system cover must be installed for the new storage controller to turn on.

**i** | **NOTE:** To verify if the storage controller is powered on, see [Storage Controller Card Indicators](#).

# Storage controller indicators



**Figure 70. Storage controller indicators**

- 1 power indicator on system board
- 2 attention indicator on system board
- 3 power indicator on storage controller card

The storage controller indicators provide the following information:

Indicator	Description
Power indicator on system board	<b>Steady Green</b> The storage controller slot is receiving power.
	<b>Blinking Green</b> The storage controller is in a fault condition.
	<b>Off</b> Power supply to the storage controller slot is off, and the controller can be removed.
Attention indicator on system board	<b>Steady Amber</b> The storage controller slot is in a fault condition.
	<b>Blinking Amber</b> The indicator blinks for 15 seconds after the slot identify command.
	<b>Off</b> The storage controller slot is operating normally.

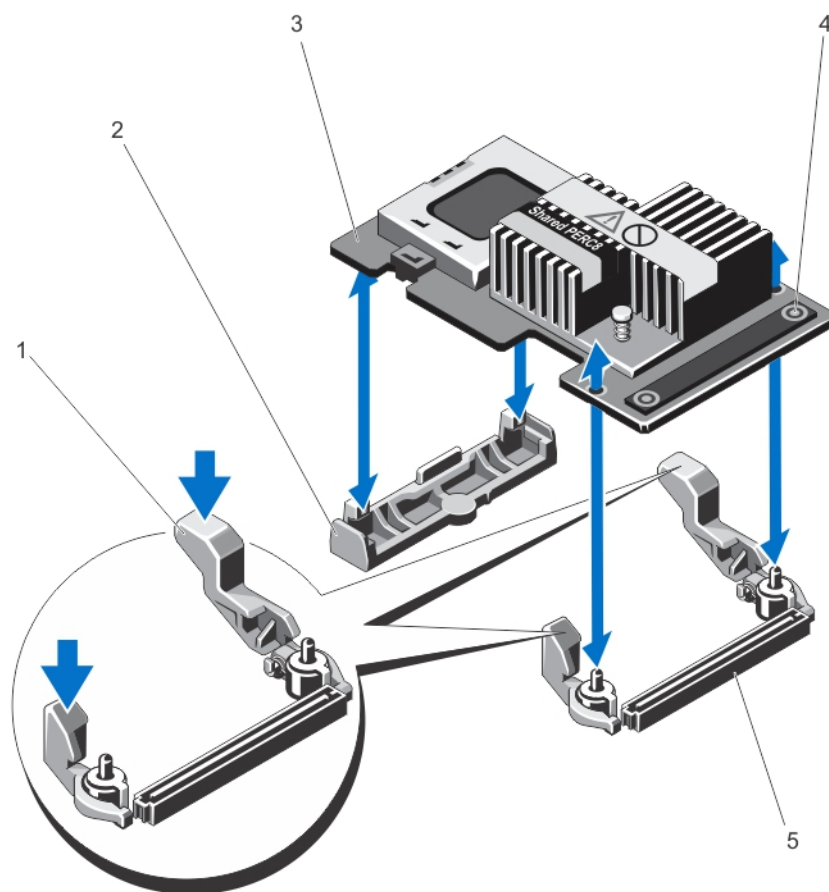


Indicator	Description	
Power indicator on storage controller card	Regular Blinking Green	The storage controller card is operating normally.
	Irregular Blinking Green	The storage controller card is in a fault condition.
	Off	The storage controller card is not receiving power.

## Removing an integrated storage controller card

**CAUTION:** Many repairs may only be done by a certified service technician. You should only perform troubleshooting and simple repairs as authorized in your product documentation, or as directed by the online or telephone service and support team. Damage due to servicing that is not authorized by Dell is not covered by your warranty. Read and follow the safety instructions that are shipped with your product.

- 1 If installed, remove the front bezel.
- 2 Turn off the server modules using the operating system commands or the CMC.
- 3 Turn off the enclosure, including any attached peripherals, and disconnect the enclosure from the electrical outlet and peripherals.
- 4 To reduce the chassis weight, remove the following (if required):
  - a hard drives
  - b server modules
  - c power supply units
- 5 If applicable, rotate the system feet inward and lay the system on its side on a flat stable surface, with the cover release latch side on top.
- 6 Open the system.
- 7 Push down the two release levers at the edge of the card to disengage the card from the connector.
- 8 Orient the card so that the other end of the card disengages from the storage-controller card holder on the system board.



**Figure 71. Removing and installing an integrated storage controller card**

- |   |   |   |                                |
|---|---|---|--------------------------------|
| 1 | release levers (2)                                    | 2 | storage-controller card holder |
| 3 | storage controller card                               | 4 | touch points (2)               |
| 5 | storage-controller card connector on the system board |   |                                |

## Installing an integrated storage controller card

**⚠ CAUTION:** Many repairs may only be done by a certified service technician. You should only perform troubleshooting and simple repairs as authorized in your product documentation, or as directed by the online or telephone service and support team. Damage due to servicing that is not authorized by Dell is not covered by your warranty. Read and follow the safety instructions that are shipped with your product.

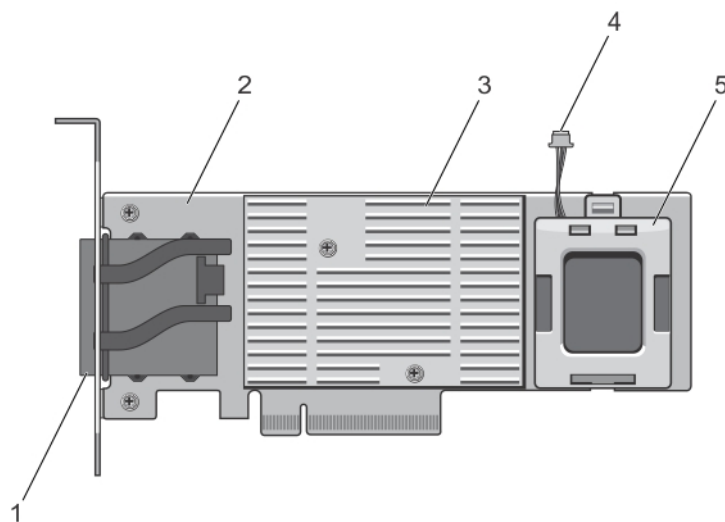
- 1 Align one end of the card with the card holder on the system board.
- 2 Lower the other end of the card into the storage-controller card holder on the system board.
- 3 Press the touch-points on the card and push the card down until it is fully seated.  
When the card is fully seated, the release levers snap over the edge of the card.
- 4 Close the system.
- 5 If applicable, place the system upright on a flat, stable surface and rotate the system feet outward.
- 6 If removed, reinstall the hard drives, server modules, and power supply units.
- 7 Reconnect the enclosure to its electrical outlet and turn the enclosure on, including any attached peripherals.
- 8 Turn on the server modules using the operating system commands or the CMC.
- 9 If applicable, install the front bezel.

# Shared PERC 8 External card

The Dell Shared PowerEdge RAID controller (PERC) 8 card is a server controller designed specifically for the Dell PowerEdge VRTX system. The Shared PERC 8 card supports Single Root Input Output Virtualization (SR-IOV), which allows multiple systems to share the available hardware resources.

The controller allows four server modules to access a local storage. Each server module's operating system (OS) loads a Virtual Function (VF) driver that allows the server module to communicate with the Shared PERC 8 firmware. Virtual disks located on the shared storage can then be mapped to a server module. From a single server module, you can only access the virtual disks that are mapped to that server module.

The Shared PERC 8 External card extends storage capacity by allowing server modules to access up to two external Just a Bunch Of Disks (JBODs). The Shared PERC 8 External cards are connected through PCIe slots 5 and 6 on the VRTX system. Shared PERC 8 External card supports MD1200 or MD1220 JBOD.



**Figure 72. Features of Shared PERC 8 External card**

- 1 external cable connectors
- 2 Shared PERC External card
- 3 heat sink
- 4 battery cable
- 5 battery

For information about installing and removing the Shared PERC 8 External card, see *Dell Shared PowerEdge RAID Controller (PERC) 8 cards For Dell PowerEdge VRTX Systems User's Guide* at [Dell.com/poweredgemanuals](https://www.dell.com/poweredge/manuals).

For information about upgrading VRTX system to support storage expansion, see *Upgrading PowerEdge VRTX to support Storage Expansion* at [Dell.com/poweredgemanuals](https://www.dell.com/poweredge/manuals).

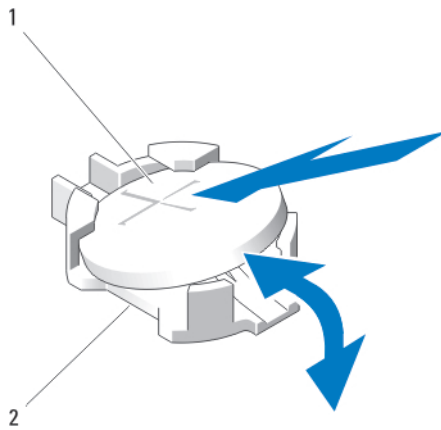
# System battery

## Replacing the system battery

**⚠ WARNING:** There is a danger of a new battery exploding if it is incorrectly installed. Replace the battery only with the same or equivalent type recommended by the manufacturer. For more information, see the safety information that shipped with your system.

**⚠ CAUTION:** Many repairs may only be done by a certified service technician. You should only perform troubleshooting and simple repairs as authorized in your product documentation, or as directed by the online or telephone service and support team. Damage due to servicing that is not authorized by Dell is not covered by your warranty. Read and follow the safety instructions that are shipped with your product.

- 1 If installed, remove the front bezel.
- 2 Turn off the server modules using the operating system commands or the CMC.
- 3 Turn off the enclosure, including any attached peripherals, and disconnect the enclosure from the electrical outlet and peripherals.
- 4 To reduce the chassis weight, remove the following (if required):
  - a hard drives
  - b server modules
  - c power supply units (PSUs)
- 5 If applicable, rotate the system feet inward and lay the system on its side on a flat stable surface, with the cover release latch side on top.
- 6 Open the system.
- 7 Remove the cooling shroud.
- 8 Remove the cooling fan assembly.
- 9 Locate the battery socket.
- 10 To remove the battery, press down firmly on the positive side of the connector and lift the battery out of the securing tabs at the negative side of the connector.
- 11 To install a new system battery:
  - a Support the battery connector by pressing down firmly on the positive side of the connector.
  - b Hold the battery with the "+" facing up and slide it under the securing tabs at the positive side of the connector.
- 12 Press the battery straight down into the connector until it snaps into place.
- 13 Reinstall the cooling fan assembly.
- 14 Reinstall the cooling shroud.
- 15 Close the system.
- 16 If applicable, place the system upright and on a flat, stable surface and rotate the system feet outward.
- 17 If removed, reinstall the hard drives, server modules, and PSUs.
- 18 Reconnect the enclosure to the electrical outlet and turn the enclosure on, including any attached peripherals.
- 19 Turn on the server modules using the operating system commands or the CMC.
- 20 If applicable, install the front bezel.
- 21 Log in to the CMC web interface and enter the correct time and date. For more information, see the *Dell Chassis Management Controller for Dell PowerEdge VRTX User's Guide* at [Dell.com/esmmanuals](https://www.dell.com/esmmanuals).



**Figure 73. Replacing the system battery**

1 positive side of battery

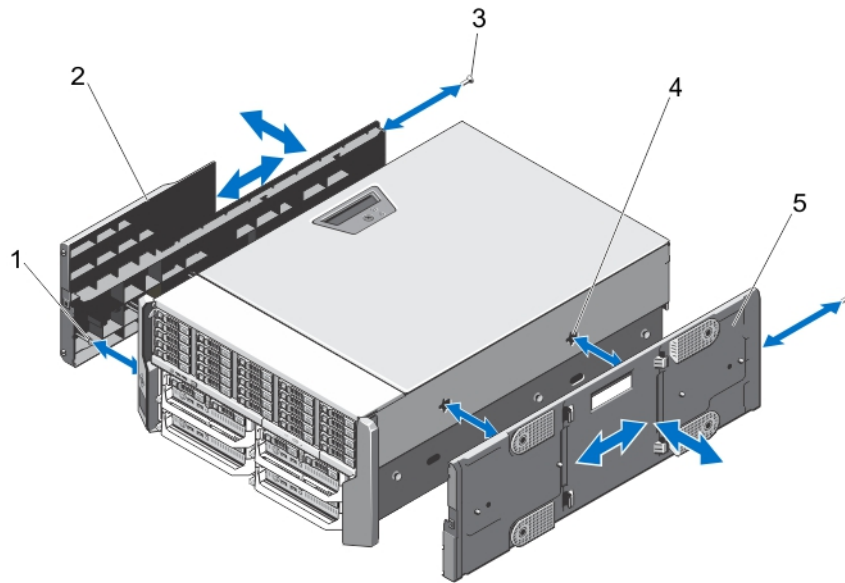
2 negative side of battery connector

## System top and base covers

### Removing the system top and base covers

**CAUTION:** Many repairs may only be done by a certified service technician. You should only perform troubleshooting and simple repairs as authorized in your product documentation, or as directed by the online or telephone service and support team. Damage due to servicing that is not authorized by Dell is not covered by your warranty. Read and follow the safety instructions that are shipped with your product.

- 1 If installed, remove the front bezel.
- 2 Turn off the server modules using the operating system commands or the CMC.
- 3 Turn off the enclosure, including any attached peripherals, and disconnect the enclosure from its electrical outlet.
- 4 If applicable, remove the power cable retention bracket.
- 5 To reduce the chassis weight, remove the following (if required):
  - a hard drives
  - b server modules
  - c power supply units
- 6 Rotate the system feet inward and lay the system on its side on a flat stable surface, with the cover release latch side on top.
- 7 To remove the top cover:
  - a Extend the top of the system slightly off the surface edge.
  - b Open the system.
  - c Remove the PCIe cage door.
  - d Remove the screw securing the top cover to the chassis.
  - e Slide the cover toward the back of the system and lift it away from the chassis.
- 8 To remove the base cover:
  - a Extend the base of the system slightly off the surface edge.
  - b If installed, remove the wheel assembly.
  - c Remove the screw securing the base cover to the chassis.
  - d Slide the cover toward the back of the system and lift it away from the chassis.



**Figure 74. Removing and installing the system top and base covers**

- |   |   |   |                  |
|---|---|---|------------------|
| 1 | tabs on the inside of top and base covers | 2 | system top cover |
| 3 | screws (2)                                | 4 | chassis slots    |
| 5 | system base cover                         |   |                  |

## Installing the system top and base covers

**CAUTION:** Many repairs may only be done by a certified service technician. You should only perform troubleshooting and simple repairs as authorized in your product documentation, or as directed by the online or telephone service and support team. Damage due to servicing that is not authorized by Dell is not covered by your warranty. Read and follow the safety instructions that are shipped with your product.

**NOTE:** To install the top cover, extend the top of the system slightly off the surface edge. To install the base cover, extend the base of the system slightly off the surface edge.

- 1 Align the tabs on the inside of the covers, with the slots on the chassis.
- 2 Lower the covers to the chassis and slide the covers toward the front of the system, until firmly seated. When firmly seated, the hooks on the covers align with the slots on the mounting ears.
- 3 Install the screws to secure the covers to the chassis.
- 4 Reinstall the PCIe cage door.
- 5 Close the system.
- 6 If applicable, reinstall the wheel assembly.
- 7 Place the system upright on a flat, stable surface. If the wheel assembly is not installed, rotate the system feet outward.
- 8 If applicable, reinstall the power cable retention bracket and route the power supply unit (PSU) cables through it.
- 9 If removed, reinstall the hard drives, server modules, and PSUs.
- 10 Reconnect the enclosure to its electrical outlet and turn the enclosure on, including any attached peripherals.
- 11 Turn on the server modules using the operating system commands or the CMC.
- 12 If applicable, install the front bezel.

# Mounting ears

Use the following procedures when:

- Replacing the top and bottom mounting ears
- Replacing the LCD module

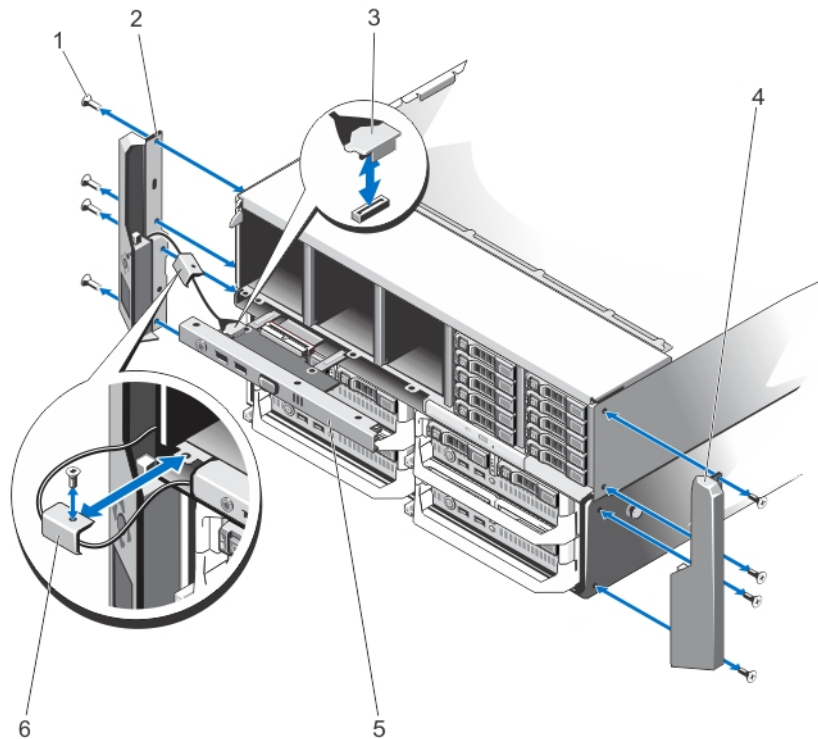
① **NOTE:** The LCD module is a part of the top mounting ear assembly. To replace the LCD module, you must replace the top mounting ear. The new top mounting ear has the replacement LCD module.

## Removing the mounting ears

△ **CAUTION:** Exercise care while removing and installing the top mounting ear, to prevent damage to the LCD module.

△ **CAUTION:** Many repairs may only be done by a certified service technician. You should only perform troubleshooting and simple repairs as authorized in your product documentation, or as directed by the online or telephone service and support team. Damage due to servicing that is not authorized by Dell is not covered by your warranty. Read and follow the safety instructions that are shipped with your product.

- 1 If installed, remove the front bezel.
- 2 Turn off the server modules using the operating system commands or the CMC.
- 3 Turn off the enclosure, including any attached peripherals, and disconnect the enclosure from the electrical outlet.
- 4 To reduce the chassis weight, remove the following (if required):
  - a hard drives
  - b server modules
  - c power supply units
- 5 Rotate the system feet inward and lay the system on its side on a flat stable surface, with the cover release latch side on top.
- 6 Open the system.
- 7 Remove the following:
  - a PCIe cage door
  - b system top cover
- 8 If applicable, remove the wheel assembly and power cable retention bracket.
- 9 Remove the system base cover.
- 10 To remove the top mounting ear:
  - a Remove the screw securing the LCD cable holder to the chassis and pull the holder out of the chassis.  
Note the routing of the LCD module cable as you remove the cable holder. You must route the cable properly when you replace the holder, to prevent it from being pinched or crimped.
  - b Remove the three screws securing the control panel to the chassis.
  - c Pressing the release tabs inward to release the control panel, slide the control panel out of the chassis by 5 cm.
  - d Disconnect the LCD module cable from the control panel.
- 11 Remove the screws securing the mounting ears to the chassis, and remove the mounting ears from the chassis.



**Figure 75. Removing and installing the mounting ears**

- |   |                  |   |                     |
|---|------------------|---|---------------------|
| 1 | screws (8)       | 2 | top mounting ear    |
| 3 | LCD module cable | 4 | bottom mounting ear |
| 5 | control panel    | 6 | LCD cable holder    |

## Installing the mounting ears

**⚠ CAUTION:** Many repairs may only be done by a certified service technician. You should only perform troubleshooting and simple repairs as authorized in your product documentation, or as directed by the online or telephone service and support team. Damage due to servicing that is not authorized by Dell is not covered by your warranty. Read and follow the safety instructions that are shipped with your product.

- 1 Align the slots on the mounting ears with the metal tabs on the chassis.  
When properly aligned, the screw holes on the mounting ears align with the screw holes on the chassis.
- 2 Attach the screws to secure the mounting ears to the chassis.
- 3 To install the top mounting ear:
  - a Route the LCD cable properly to prevent it from being pinched or crimped.
  - b Align the slot on the cable holder with the metal standoff on the chassis, and slide the holder into the chassis.
  - c Install the screw to secure the cable holder to the chassis.
  - d Reconnect the LCD module cable to the control panel.
  - e Slide the control panel into the chassis and install the screws to secure the panel to the chassis.
- 4 Reinstall the following:
  - a system top cover
  - b PCIe cage door
- 5 Reinstall the system base cover.
- 6 Close the system.
- 7 If applicable, reinstall the wheel assembly and power cable retention bracket.



- 8 Place the system upright on a flat, stable surface.  
If the wheel assembly is not installed, rotate the system feet outward.
- 9 If removed, reinstall the hard drives, server modules, and power supply units.
- 10 Reconnect the enclosure to its electrical outlet and turn the enclosure on, including any attached peripherals.
- 11 Turn on the server modules using the operating system commands or the CMC.
- 12 If applicable, install the front bezel.

## Replacing the LCD module

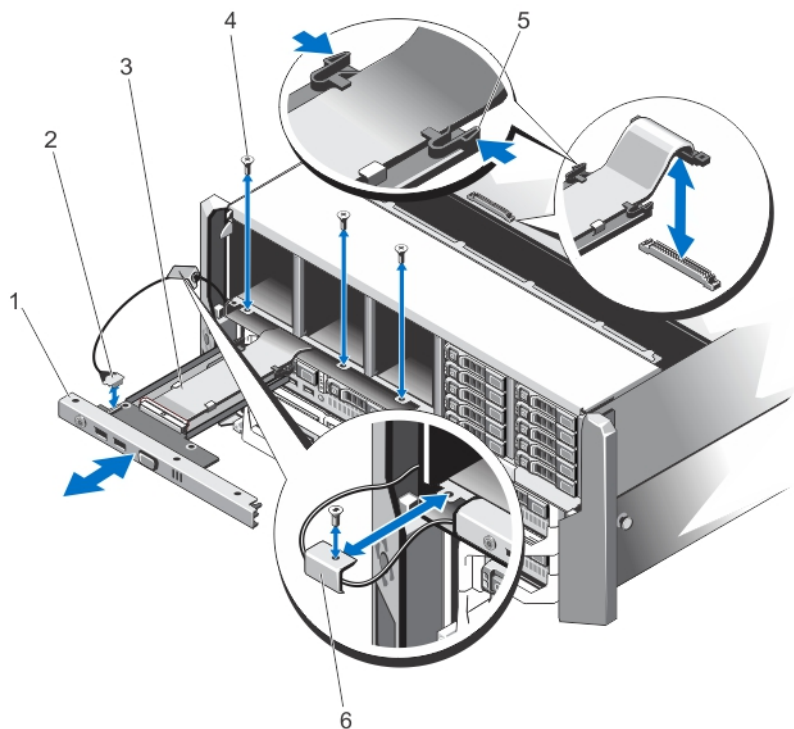
The LCD module is a part of the top mounting ear assembly. To replace an LCD module, you must replace the top mounting ear. The new top mounting ear will have the replacement LCD module. For information on removing and installing the top mounting ear, see [Removing The Mounting Ears](#) and [Installing The Mounting Ears](#).

## Control panel assembly

### Removing the control panel

**⚠ CAUTION: Many repairs may only be done by a certified service technician. You should only perform troubleshooting and simple repairs as authorized in your product documentation, or as directed by the online or telephone service and support team. Damage due to servicing that is not authorized by Dell is not covered by your warranty. Read and follow the safety instructions that came with the product.**

- 1 If installed, remove the front bezel.
- 2 Turn off the server modules using the operating system commands or the CMC.
- 3 Turn off the enclosure, including any attached peripherals, and disconnect the enclosure from the electrical outlet and peripherals.
- 4 Remove the server modules installed in Slots 1 and 2.
- 5 Remove the hard drives installed in Slots 0 to 5 of the 3.5-inch hard drive chassis, and Slots 0 to 14 of the 2.5-inch hard drive chassis.
- 6 If applicable, rotate the system feet inward and lay the system on its side on a flat stable surface, with the cover release latch side on top.
- 7 Open the system.
- 8 Remove the cooling shroud.
- 9 Remove the cooling fan assembly.
- 10 Disconnect the control panel cable from its connector on the system board.
- 11 Remove the screw securing the LCD cable holder to the chassis and pull the cable holder out of the chassis.  
Note the routing of the LCD module cable as you remove the cable holder. You must route the cable properly when you replace the holder, to prevent it from being pinched or crimped.
- 12 Remove the three screws securing the control panel to the chassis.
- 13 Press the release tabs inward to release the control panel.
- 14 Holding it by its sides, pull the control panel out of the chassis.
- 15 Use the pull-tab to disconnect the LCD module cable from the control panel board.



**Figure 76. Removing and installing the control panel**

- |   |                     |   |                  |
|---|---------------------|---|------------------|
| 1 | control panel       | 2 | LCD module cable |
| 3 | control panel cable | 4 | screws (3)       |
| 5 | release tabs (2)    | 6 | LCD cable holder |

## Installing the control panel

**⚠ CAUTION:** Many repairs may only be done by a certified service technician. You should only perform troubleshooting and simple repairs as authorized in your product documentation, or as directed by the online or telephone service and support team. Damage due to servicing that is not authorized by Dell is not covered by your warranty. Read and follow the safety instructions that came with the product.

- 1 Route the LCD module cable properly to prevent it from being pinched or crimped.
- 2 Align the slot on the cable holder with the metal standoff on the chassis.
- 3 Slide the cable holder into the chassis, and install the screw to secure it to the chassis.
- 4 Connect the LCD module cable to the new control panel.
- 5 Align the slots on the sides of the control panel with the metal standoffs on the chassis.
- 6 Slide the control panel into the chassis.  
Ensure that the LCD module cable is not pinched or crimped.
- 7 Install the three screws to secure the control panel to the chassis.
- 8 Reconnect the control panel cable to the system board.
- 9 Reinstall the cooling fan assembly.
- 10 Reinstall the cooling shroud.
- 11 Close the system.
- 12 If applicable, place the system upright on a flat, stable surface and rotate the system feet outward.
- 13 Reinstall the hard drives.

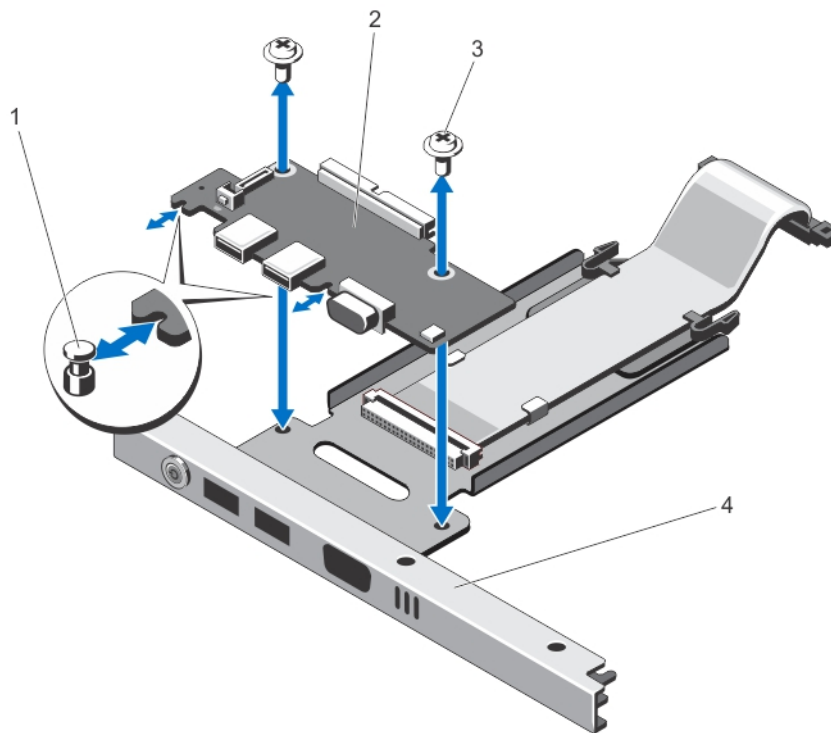
- 14 Reinstall the server modules.
- 15 Reconnect the enclosure to its electrical outlet and turn the enclosure on, including any attached peripherals.
- 16 Turn on the server modules using the operating system commands or the CMC.
- 17 If applicable, install the front bezel.

## Removing the control panel board

**⚠ CAUTION:** This procedure is intended to be performed by Dell Support only.

**⚠ CAUTION:** Many repairs may only be done by a certified service technician. You should only perform troubleshooting and simple repairs as authorized in your product documentation, or as directed by the online or telephone service and support team. Damage due to servicing that is not authorized by Dell is not covered by your warranty. Read and follow the safety instructions that are shipped with your product.

- 1 If installed, remove the front bezel.
- 2 Turn off the server modules using the operating system commands or the CMC.
- 3 Turn off the enclosure, including any attached peripherals, and disconnect the enclosure from the electrical outlet and peripherals.
- 4 Remove the server modules installed in Slots 1 and 2.
- 5 Remove the hard drives installed in Slots 0 to 5 of the 3.5-inch hard drive chassis, and Slots 0 to 14 of the 2.5-inch hard drive chassis.
- 6 If applicable, rotate the system feet inward and lay the system on its side on a flat stable surface, with the cover release latch side on top.
- 7 Open the system.
- 8 Remove the cooling shroud.
- 9 Remove the cooling fan assembly.
- 10 Disconnect the control panel cable from its connector on the system board.
- 11 Remove the LCD cable holder.
- 12 Remove the control panel.
- 13 Disconnect the LCD module cable from the control panel board.
- 14 Disconnect the power cable from the control panel board.
- 15 Remove the two screws securing the control panel board to the control panel.
- 16 Slide the control panel board out of the control panel.



**Figure 77. Removing and installing the control panel board**

- |   |                     |   |                     |
|---|---------------------|---|---------------------|
| 1 | metal standoffs (2) | 2 | control panel board |
| 3 | screws (2)          | 4 | control panel       |

## Installing the control panel board

**⚠ CAUTION:** This procedure is intended to be performed by Dell Support only.

**⚠ CAUTION:** Many repairs may only be done by a certified service technician. You should only perform troubleshooting and simple repairs as authorized in your product documentation, or as directed by the online or telephone service and support team. Damage due to servicing that is not authorized by Dell is not covered by your warranty. Read and follow the safety instructions that are shipped with your product.

- 1 Align the slots on the control panel board with the metal standoffs on the control panel and slide the control panel board into the control panel.  
When firmly seated, the KVM connectors on the control panel board align with the slots on the control panel.
- 2 Attach the two screws to secure the control panel board to the control panel.
- 3 Reconnect the power cable to the control panel board.
- 4 Reconnect the LCD module cable to the control panel board.
- 5 Reinstall the LCD cable holder.
- 6 Reinstall the control panel.
- 7 Reconnect the control panel cable to its connector on the system board.
- 8 Reinstall the cooling fan assembly.
- 9 Reinstall the cooling shroud.
- 10 Close the system.
- 11 If applicable, place the system upright on a flat, stable surface and rotate the system feet outward.
- 12 Reinstall the hard drives.

- 13 Reinstall the server modules.
- 14 Reconnect the enclosure to its electrical outlet and turn the enclosure on, including any attached peripherals.
- 15 Turn on the server modules using the operating system commands or the CMC.
- 16 If applicable, install the front bezel.

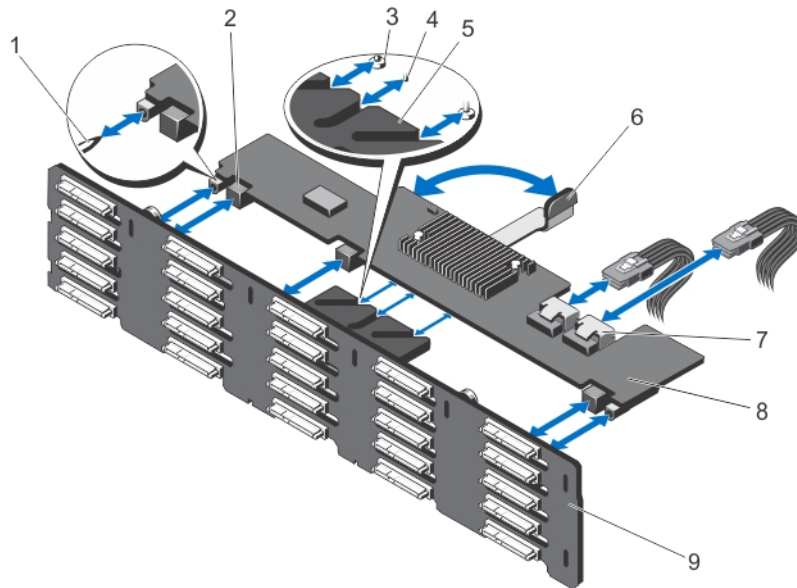
## Backplane expander boards

Your system supports up to two backplane expander boards.

### Removing a backplane expander board

**⚠ CAUTION:** Many repairs may only be done by a certified service technician. You should only perform troubleshooting and simple repairs as authorized in your product documentation, or as directed by the online or telephone service and support team. Damage due to servicing that is not authorized by Dell is not covered by your warranty. Read and follow the safety instructions that are shipped with your product.

- 1 If installed, remove the front bezel.
- 2 Turn off the server modules using the operating system commands or the CMC.
- 3 Turn off the enclosure, including any attached peripherals, and disconnect the enclosure from the electrical outlet and peripherals.
- 4 To reduce the chassis weight, remove the following (if required):
  - a hard drives
  - b server modules
  - c power supply units
- 5 If applicable, rotate the system feet inward and lay the system on its side on a flat stable surface, with the cover release latch side on top.
- 6 Open the system.
- 7 Remove the cooling shroud.
- 8 Remove the cooling fan assembly.
- 9 Disconnect the SAS cables from the backplane expander board.
- 10 Rotate the release lever outward to disengage the expander board connectors from the connectors on the hard drive backplane.
- 11 Remove the backplane expander board from the connectors on the hard drive backplane.



**Figure 78. Removing and installing a backplane expander board**

- |   |   |   |  |
|---|---|---|--|
| 1 | guide pins on the hard drive backplane (2)                          | 2 | backplane expander board connectors (3)                  |
| 3 | securing screws on the release lever (under the expander board) (2) | 4 | standoff on the release lever (under the expander board) |
| 5 | expander board bracket  | 6 | release lever  |
| 7 | SAS cable connectors (2)  | 8 | backplane expander board                                 |
| 9 | hard drive backplane  |   |  |

## Installing a backplane expander board

**CAUTION:** Many repairs may only be done by a certified service technician. You should only perform troubleshooting and simple repairs as authorized in your product documentation, or as directed by the online or telephone service and support team. Damage due to servicing that is not authorized by Dell is not covered by your warranty. Read and follow the safety instructions that are shipped with your product.

- 1 Align the slots on the two ends of the backplane expander board with the guide pins on the hard drive backplane.
- 2 Holding the backplane expander board by the release lever, slide it into the connectors on the hard drive backplane, until fully seated. The securing screws and standoff on the release lever (under the expander board) slide into the slots on the expander board bracket on the hard drive backplane.
- 3 Rotate the release lever inward until it is level with the expander board and the expander board connectors engage with the hard drive backplane connectors.
- 4 Connect the SAS cables to the backplane expander board.
- 5 Reinstall the cooling fan assembly.
- 6 Reinstall the cooling shroud.
- 7 Close the system.
- 8 If applicable, place the system upright on a flat, stable surface and rotate the system feet outward.
- 9 If removed, reinstall the hard drives, server modules, and power supply units.
- 10 Reconnect the enclosure to its electrical outlet and turn the enclosure on, including any attached peripherals.
- 11 Turn on the server modules using the operating system commands or the CMC.
- 12 If applicable, install the front bezel.

# Hard drive backplane

Depending on your system configuration:

25–Hard Drive System Supports	2.5-inch SAS or SAS-SSD backplane
12–Hard Drive System Supports	3.5-inch SAS or SAS-SSD backplane

## Removing the hard drive backplane

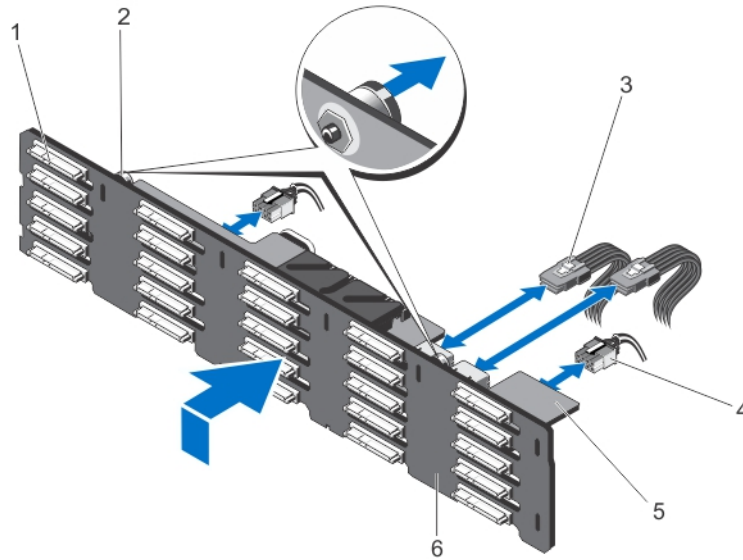
**CAUTION:** Many repairs may only be done by a certified service technician. You should only perform troubleshooting and simple repairs as authorized in your product documentation, or as directed by the online or telephone service and support team. Damage due to servicing that is not authorized by Dell is not covered by your warranty. Read and follow the safety instructions that are shipped with your product.

- 1 If installed, remove the front bezel.
- 2 Turn off the server modules using the operating system commands or the CMC.
- 3 Turn off the enclosure, including any attached peripherals, and disconnect the enclosure from the electrical outlet.
- 4 To reduce the chassis weight, remove the following (if required):
  - a hard drives
  - b server modules
  - c power supply units
- 5 If applicable, rotate the system feet inward and lay the system on its side on a flat stable surface, with the cover release latch side on top.
- 6 Open the system.

**CAUTION:** To prevent damage to the hard drives and hard drive backplane, you must remove the hard drives from the enclosure before removing the hard drive backplane.

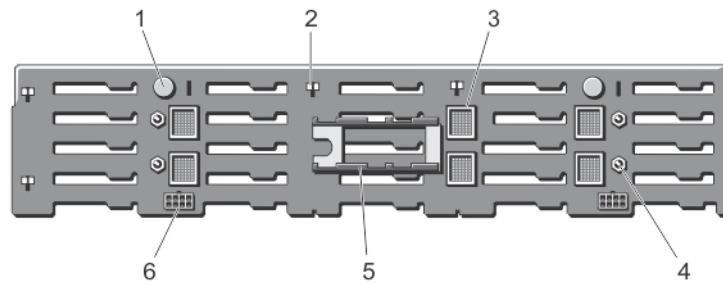
**CAUTION:** You must note the number of each hard drive and temporarily label them before removal so that you can replace them in the same locations.

- 7 Remove all hard drives.
- 8 Remove the cooling shroud.
- 9 Remove the cooling fan assembly.
- 10 Remove the backplane expander board.
- 11 Disconnect the power cables from the backplane.
- 12 If applicable, disconnect the power and data cable from the optical drive.
- 13 Pull the backplane release pins in the direction of the system board and lift the backplane from the chassis.



**Figure 79. Removing and installing the 2.5-inch (x25) hard drive backplane**

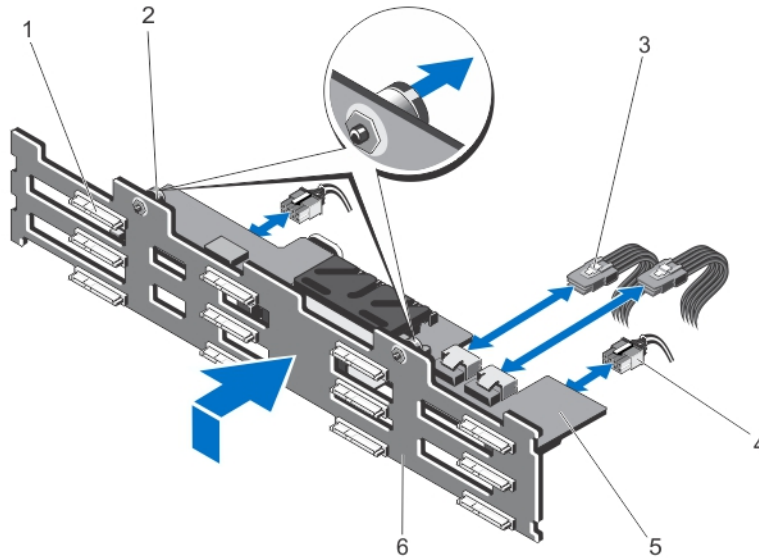
- |   |  |   |                      |
|---|--|---|----------------------|
| 1 | hard drive connectors (25)                 | 2 | release pins (2)     |
| 3 | SAS cables on backplane expander board (2) | 4 | power cables (2)     |
| 5 | backplane expander board                   | 6 | hard drive backplane |



**Figure 80. Back view of the 2.5-inch (x25) hard drive backplane**

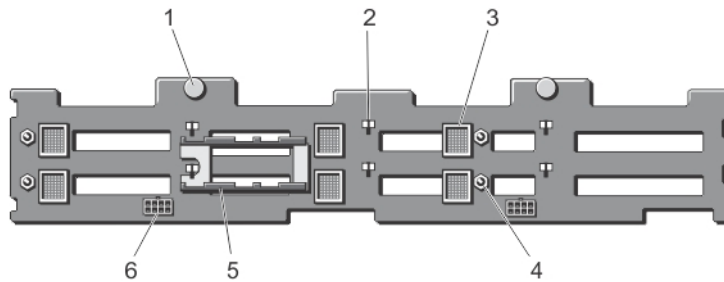
- |   |   |   |  |
|---|---|---|--|
| 1 | release pins (2)                        | 2 | slots for chassis hooks (10)                     |
| 3 | backplane expander board connectors (6) | 4 | guide pins for the backplane expander boards (4) |
| 5 | backplane expander board brackets (2)   | 6 | power cable connectors (2)                       |





**Figure 81. Removing and installing the 3.5-inch (x12) hard drive backplane**

- |   |  |   |                      |
|---|--|---|----------------------|
| 1 | hard drive connectors (12)                 | 2 | release pins (2)     |
| 3 | SAS cables on backplane expander board (2) | 4 | power cables (2)     |
| 5 | backplane expander board                   | 6 | hard drive backplane |



**Figure 82. Back view of the 3.5-inch (x12) hard drive backplane**

- |   |   |   |  |
|---|---|---|--|
| 1 | release pins (2)                        | 2 | slots for chassis hooks (10)                 |
| 3 | backplane expander board connectors (6) | 4 | guide pins for backplane expander boards (4) |
| 5 | backplane expander board brackets (2)   | 6 | power cable connectors (2)                   |

## Installing the hard drive backplane

**CAUTION:** Many repairs may only be done by a certified service technician. You should only perform troubleshooting and simple repairs as authorized in your product documentation, or as directed by the online or telephone service and support team. Damage due to servicing that is not authorized by Dell is not covered by your warranty. Read and follow the safety instructions that are shipped with your product.

- 1 Align the slots on the hard drive backplane with the hooks on the chassis.
- 2 Slide down the hard drive backplane until the release pins align with the slots on the chassis and click into place.
- 3 Connect the power cables to the hard drive backplane.
- 4 Route the power cables along the chassis base.
- 5 If applicable, connect the power and data cable to the optical drive.

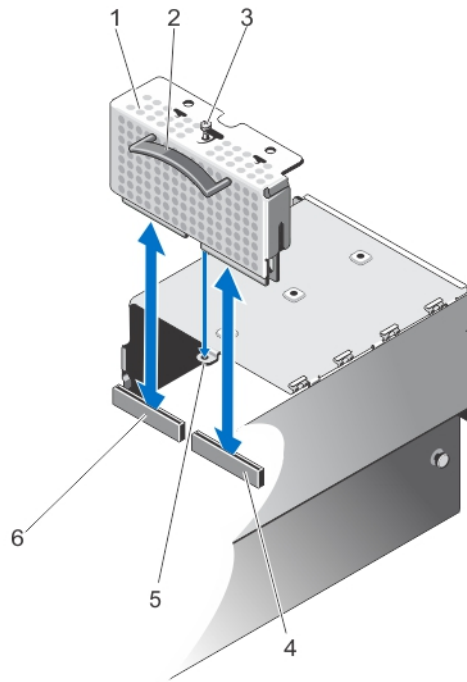
- 6 Reinstall the backplane expander board.
- 7 Reinstall the cooling fan assembly.
- 8 Reinstall the cooling shroud.
- 9 Install the hard drives in their original locations.
- 10 Close the system.
- 11 If applicable, place the system upright and on its feet on a flat, stable surface.
- 12 If removed, reinstall the hard drives, server modules, and power supply units.
- 13 Reconnect the enclosure to its electrical outlet and turn the enclosure on, including any attached peripherals.
- 14 Turn on the server modules using the operating system commands or the CMC.
- 15 If applicable, install the front bezel.

## Power distribution board

### Removing the power distribution board

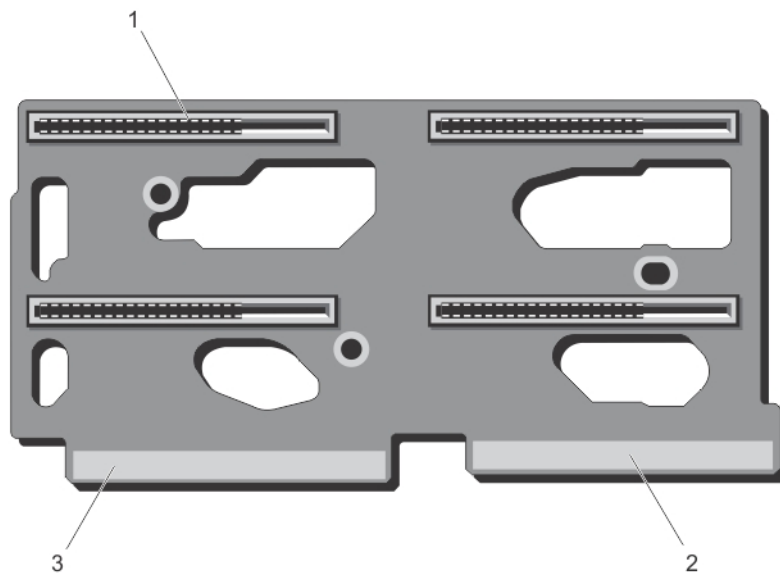
**⚠ CAUTION:** Many repairs may only be done by a certified service technician. You should only perform troubleshooting and simple repairs as authorized in your product documentation, or as directed by the online or telephone service and support team. Damage due to servicing that is not authorized by Dell is not covered by your warranty. Read and follow the safety instructions that are shipped with your product.

- 1 If installed, remove the front bezel.
- 2 Turn off the server modules using the operating system commands or the CMC.
- 3 Turn off the enclosure, including any attached peripherals, and disconnect the enclosure from the electrical outlet and peripherals.
- 4 To reduce the chassis weight, remove the following (if required):
  - a hard drives
  - b server modules
- 5 Remove the power supply units (PSUs).
- 6 If applicable, rotate the system feet inward and lay the system on its side on a flat stable surface, with the cover release latch side on top.
- 7 Open the system.
- 8 Loosen the spring-loaded screw securing the power distribution board (PDB) bracket to the PSU cage.
- 9 Holding the handle, lift the PDB bracket upward and away from the chassis.
- 10 Remove the three screws securing the PDB to the PDB bracket and remove the PDB from the bracket.



**Figure 83. Removing and installing the power distribution board**

- |   |  |   |   |
|---|--|---|---|
| 1 | PDB bracket                                | 2 | handle                                    |
| 3 | spring-loaded screw                        | 4 | PDB connector on power pass-through board |
| 5 | screw hole for PDB bracket on the PSU cage | 6 | PDB connector on the system board         |



**Figure 84. Power distribution board connectors**

- |   |                                    |   |                           |
|---|------------------------------------|---|---------------------------|
| 1 | PSU connectors (4)                 | 2 | connector to system board |
| 3 | power pass-through board connector |   |                           |

# Installing the power distribution board

**CAUTION:** Many repairs may only be done by a certified service technician. You should only perform troubleshooting and simple repairs as authorized in your product documentation, or as directed by the online or telephone service and support team. Damage due to servicing that is not authorized by Dell is not covered by your warranty. Read and follow the safety instructions that are shipped with your product.

- 1 Align the screw holes on the PDB with the screw holes on the PDB bracket.
- 2 Install the three screws to secure the PDB to the bracket.
- 3 Holding it by the handle, position the PDB bracket so that the two PDB edge connectors align with the connectors on the system board and the power pass-through board.
- 4 Aligning the slot on the PDB bracket with the metal standoffs on the chassis wall, slide the PDB into the connectors until firmly seated. When firmly seated, the spring-loaded screw on the PDB bracket aligns with the screw hole on the power supply unit (PSU) cage.
- 5 Tighten the spring-loaded screw to secure the PDB bracket to the PSU cage.
- 6 Close the system.
- 7 If applicable, place the system upright on a flat, stable surface and rotate the system feet outward.
- 8 Reinstall the PSUs.
- 9 If removed, reinstall the hard drives and server modules.
- 10 Reconnect the enclosure to its electrical outlet and turn the enclosure on, including any attached peripherals.
- 11 Turn on the server modules using the operating system commands or the CMC.
- 12 If applicable, install the front bezel.

# System board

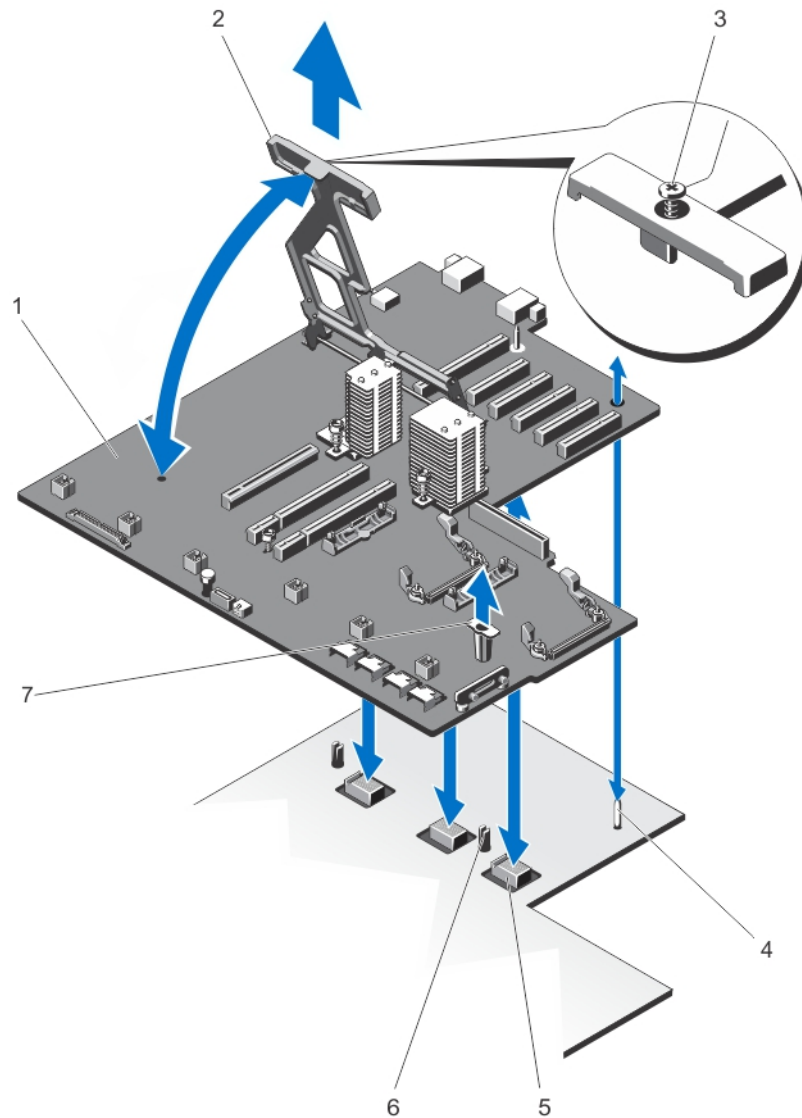
## Removing the system board

**CAUTION:** Many repairs may only be done by a certified service technician. You should only perform troubleshooting and simple repairs as authorized in your product documentation, or as directed by the online or telephone service and support team. Damage due to servicing that is not authorized by Dell is not covered by your warranty. Read and follow the safety instructions that are shipped with your product.

**CAUTION:** If you are using the Trusted Program Module (TPM) with an encryption key, you may be prompted to create a recovery key during program or System Setup. Be sure to create and safely store this recovery key. If you replace this system board, you must supply the recovery key when you restart your system or program before you can access the encrypted data on your hard drives.

- 1 If installed, remove the front bezel.
- 2 Turn off the server modules using the operating system commands or the CMC.
- 3 Turn off the enclosure, including any attached peripherals, and disconnect the enclosure from the electrical outlet.
- 4 Remove the following:
  - a hard drives
  - b power supply units
  - c server modules
- 5 If applicable, rotate the system feet inward and lay the system on its side on a flat stable surface, with the cover release latch side on top.
- 6 Open the system.
- 7 Remove the following:
  - a cooling shroud
  - b cooling fan assembly
  - c backplane expander board

- d hard drive backplane
  - e PCIe cage
  - f power distribution board
  - g CMC cards
  - h integrated storage controller card
- 8 Disconnect all cables from the system board.
  - 9 Loosen the spring-loaded screw securing the system board handle to the chassis, and lift the handle.
  - 10 Holding the system board handle on one side and the system board holder on the other side, lift the system board.
  - 11 Angling the system board toward the back of the chassis to release the CMC connectors from the chassis slots, slide the system board out of the chassis.



**Figure 85. Removing and installing the system board**

- |                                  |                       |
|----------------------------------|-----------------------|
| 1 system board                   | 2 system board handle |
| 3 spring-loaded screw            | 4 guide pin           |
| 5 midplane planar connectors (3) | 6 securing pins (2)   |
| 7 system-board holder            |                       |

## Installing the system board

**⚠ CAUTION:** Many repairs may only be done by a certified service technician. You should only perform troubleshooting and simple repairs as authorized in your product documentation, or as directed by the online or telephone service and support team. Damage due to servicing that is not authorized by Dell is not covered by your warranty. Read and follow the safety instructions that are shipped with your product.

- 1 Unpack the new system board assembly.
- 2 Holding the system board by the system board handle and the system board holder, angle it toward the back of the chassis.
- 3 Slide the system board toward the back of the chassis, until the CMC connectors align with the chassis slots.
- 4 Align the system board with the guide pins on the chassis and lower it into the chassis.
- 5 Lower the system board handle until it engages with the securing pins on the chassis.
- 6 Tighten the spring-loaded screw on the system board handle to secure it to the chassis.
- 7 Replace the following:
  - a integrated storage controller card
  - b CMC cards
  - c power distribution board
  - d PCIe cage
  - e hard drive backplane
  - f backplane expander board
  - g cooling fan assembly
  - h cooling shroud
- 8 Reconnect all cables to the system board.
- 9 Close the system.
- 10 If applicable, place the system upright on a flat, stable surface and rotate the system feet outward.
- 11 Reinstall the following:
  - a hard drives
  - b server modules
  - c power supply units
- 12 Reconnect the enclosure to its electrical outlet and turn the enclosure on, including any attached peripherals.
- 13 Turn on the server modules using the operating system commands or the CMC.
- 14 If applicable, install the front bezel.
- 15 Import your new or existing iDRAC Enterprise license. For more information, see *iDRAC7 User's Guide*, at [Dell.com/support/manuals](http://Dell.com/support/manuals).

## Power pass-through board

The power pass-through board supplies power from the power distribution board to the enclosure midplane.

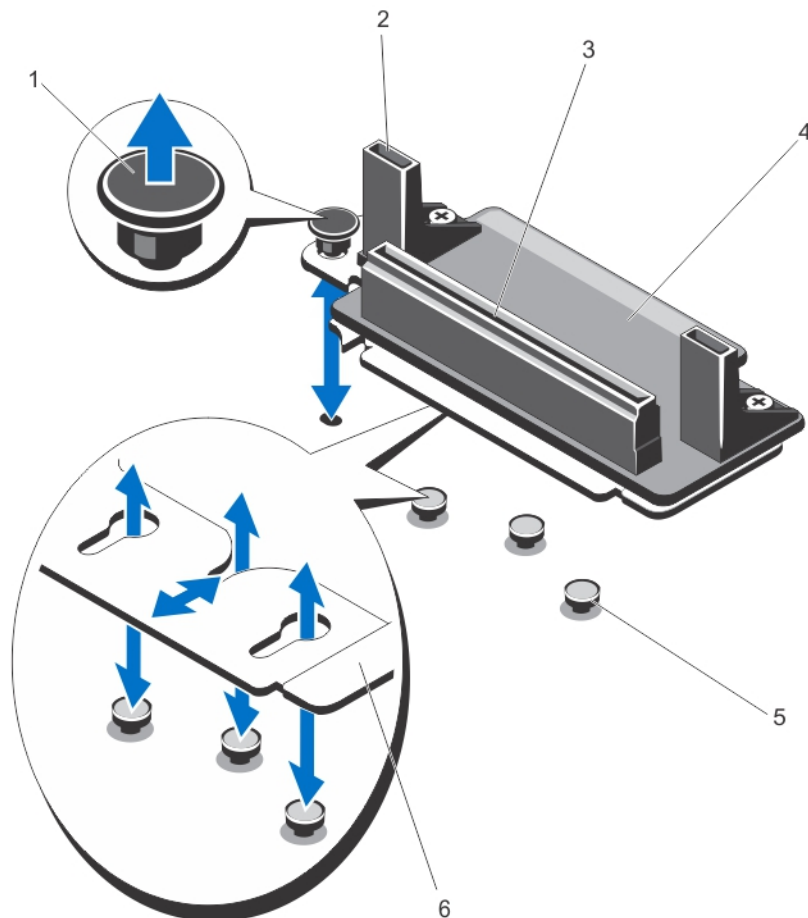
## Removing the power pass-through board

**⚠ CAUTION:** Many repairs may only be done by a certified service technician. You should only perform troubleshooting and simple repairs as authorized in your product documentation, or as directed by the online or telephone service and support team. Damage due to servicing that is not authorized by Dell is not covered by your warranty. Read and follow the safety instructions that are shipped with your product.

- 1 If installed, remove the front bezel.
- 2 Turn off the server modules using the operating system commands or the CMC.
- 3 Turn off the enclosure, including any attached peripherals, and disconnect the enclosure from the electrical outlet and peripherals.
- 4 Remove the following:

- a hard drives
  - b server modules
  - c power supply units
- 5 If applicable, rotate the system feet inward and lay the system on its side on a flat stable surface, with the cover release latch side on top.
  - 6 Open the system.
  - 7 Remove the following:
    - a cooling shroud
    - b cooling fan assembly
    - c backplane expander board
    - d hard drive backplane
    - e PCIe cage
    - f power distribution board
    - g system board
  - 8 Lift the release pin to disengage the power pass-through board from the chassis.
  - 9 Grasping the power pass-through board by its two holders, slide it toward the front of the system, to disengage the connector from the midplane.
 

The slots on the power pass-through board bracket are unlocked from the metal standoffs on the chassis.
  - 10 Lift the power pass-through board up and away from the chassis.



**Figure 86. Removing and installing the power pass-through board**

- |   |               |   |                                      |
|---|---------------|---|--------------------------------------|
| 1 | release pin   | 2 | power pass-through board holders (2) |
| 3 | PDB connector | 4 | power pass-through board             |

## Installing the power pass-through board

**⚠ CAUTION:** Many repairs may only be done by a certified service technician. You should only perform troubleshooting and simple repairs as authorized in your product documentation, or as directed by the online or telephone service and support team. Damage due to servicing that is not authorized by Dell is not covered by your warranty. Read and follow the safety instructions that are shipped with your product.

- 1 Align the slots on the power pass-through board bracket with the metal standoffs on the chassis, and lower the board into the chassis.
- 2 Grasping the power pass-through board with the holders, slide the board toward the back of the system until the connector engages with the midplane.  
When firmly seated, the slots on the power pass-through board bracket get locked with the metal standoffs and the release pin clicks into the chassis slot.
- 3 Reinstall the following:
  - a system board
  - b power distribution board
  - c PCIe cage
  - d hard drive backplane
  - e backplane expander board
  - f cooling fan assembly
  - g cooling shroud
- 4 Close the system.
- 5 If applicable, place the system upright on a flat, stable surface and rotate the system feet outward.
- 6 Reinstall the following:
  - a hard drives
  - b server modules
  - c power supply units
- 7 Reconnect the enclosure to its electrical outlet and turn the enclosure on, including any attached peripherals.
- 8 Turn on the server modules using the operating system commands or the CMC.
- 9 If applicable, install the front bezel.

## Midplane

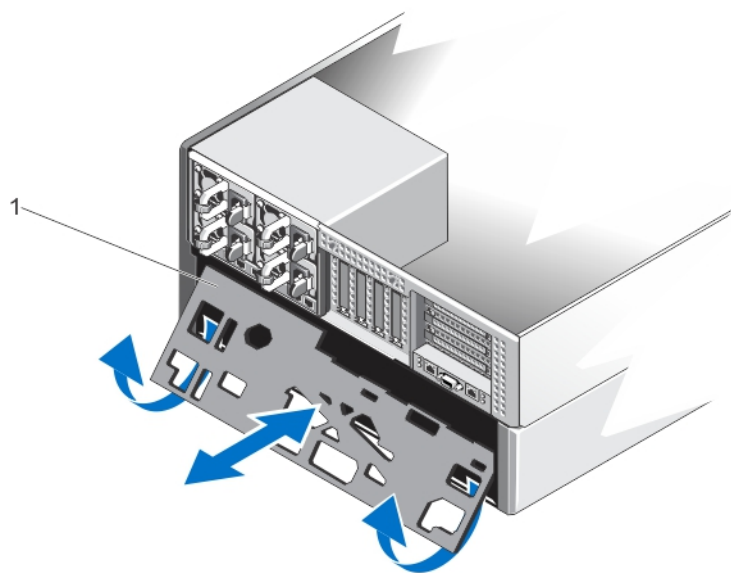
### Removing the midplane

**⚠ CAUTION:** Many repairs may only be done by a certified service technician. You should only perform troubleshooting and simple repairs as authorized in your product documentation, or as directed by the online or telephone service and support team. Damage due to servicing that is not authorized by Dell is not covered by your warranty. Read and follow the safety instructions that came with the product.

- 1 If installed, remove the front bezel.
- 2 Turn off the server modules using the operating system commands or the CMC.
- 3 Turn off the enclosure, including any attached peripherals, and disconnect the enclosure from the electrical outlet and peripherals.
- 4 Remove the following:
  - a server modules
  - b hard drives
  - c power supply units
  - d I/O module
  - e blower modules



- 5 If applicable, rotate the system feet inward and lay the system on its side on a flat stable surface, with the cover release latch side on top.
- 6 Open the system.
- 7 Remove the following:
  - a cooling shroud
  - b cooling fan assembly
  - c backplane expander board
  - d hard drive backplane
  - e PCIe cage
  - f power distribution board
  - g system board
  - h power pass-through board
  - i blower module bay
- 8 Holding the midplane by its slots, disengage the midplane from the two securing pins on the chassis.
- 9 Rotate the midplane out and away from the system.



**Figure 87. Removing and installing the midplane**

- 1 midplane

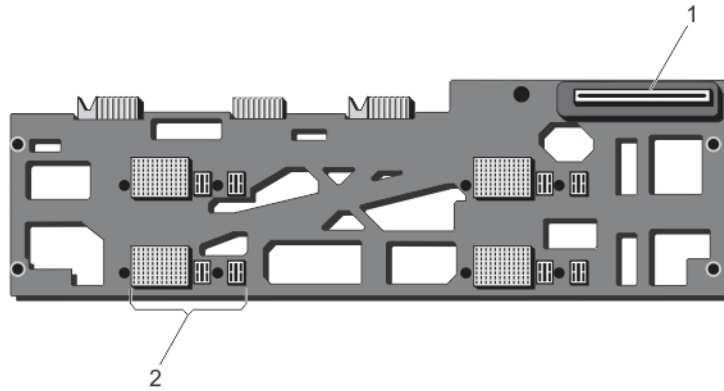


Figure 88. Front view of the midplane

- 1 power pass-through board connector
- 2 server module connectors (4)

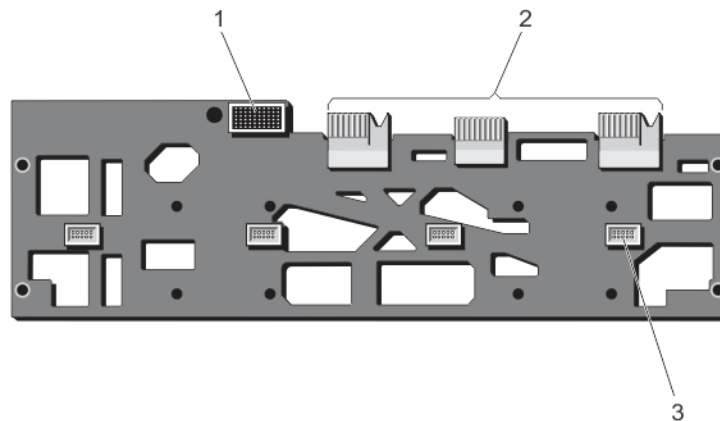


Figure 89. Back view of the midplane

- 1 I/O module connector
- 2 planar connectors (3)
- 3 blower module connectors (4)

## Installing the midplane

**CAUTION:** Many repairs may only be done by a certified service technician. You should only perform troubleshooting and simple repairs as authorized in your product documentation, or as directed by the online or telephone service and support team. Damage due to servicing that is not authorized by Dell is not covered by your warranty. Read and follow the safety instructions that came with the product.

- 1 Angle the side of the midplane with the planar connectors, and slide the midplane into the chassis. The planar connectors align with the chassis slots.
- 2 Rotate the other side of the midplane until the midplane is aligned with the two securing pins on the chassis.
- 3 Press the midplane to the chassis, until it engages with the securing pins, and is firmly seated.
- 4 Replace the following:
  - a blower module bay
  - b power pass-through board
  - c system board
  - d power distribution board
  - e PCIe cage

- f hard drive backplane
  - g backplane expander board
  - h cooling fan assembly
  - i cooling shroud
- 5 Close the system.
  - 6 If applicable, place the system upright on a flat, stable surface and rotate the system feet outward.
  - 7 Replace the following:
    - a blower modules
    - b I/O module
    - c power supply units
    - d hard drives
    - e server modules
  - 8 Reconnect the enclosure to its electrical outlet and turn the enclosure on, including any attached peripherals.
  - 9 Turn on the server modules using the operating system commands or the CMC.
  - 10 If applicable, install the front bezel.

# Converting the system from tower mode to rack mode

- △ **CAUTION:** Many repairs may only be done by a certified service technician. You should only perform troubleshooting and simple repairs as authorized in your product documentation, or as directed by the online or telephone service and support team. Damage due to servicing that is not authorized by Dell is not covered by your warranty. Read and follow the safety instructions that are shipped with your product.
- △ **CAUTION:** To maintain optimum thermal conditions, ensure that there are no obstructions to airflow on the front and back of the enclosure. The front and back of the enclosure must have at least 30 cm (12-inches) and 61 cm (24 inches) of unobstructed space respectively.

Topics:

- [Safety instructions](#)
- [Preparing a system for conversion from tower mode to rack mode](#)
- [Installing the enclosure in a rack](#)

## Safety instructions

- ① **NOTE:** For specific caution statements and procedures, see the rack installation documentation that shipped with your system and the rack kit. For complete safety and regulatory information, see the safety instructions that shipped with your system.

Observe the following precautions for stability and safety of the system in rack mode:

- Your rack kit has been approved for the rack enclosure. Ensure that installation of the equipment into any other rack complies with all applicable standards. Dell disclaims all liability and warranties with respect to combinations of equipment with any other rack.
- Before installing your equipment in a rack, install all front and side stabilizers. Failure to install stabilizers can allow the rack to tip over.
- Always load the rack from the bottom up, and load the heaviest items first.
- Do not overload the AC power supply unit branch circuit that provides power to the rack.
- Do not stand or step on any components in the rack.

## Preparing a system for conversion from tower mode to rack mode

You require the following items to convert your system from tower to rack mode:

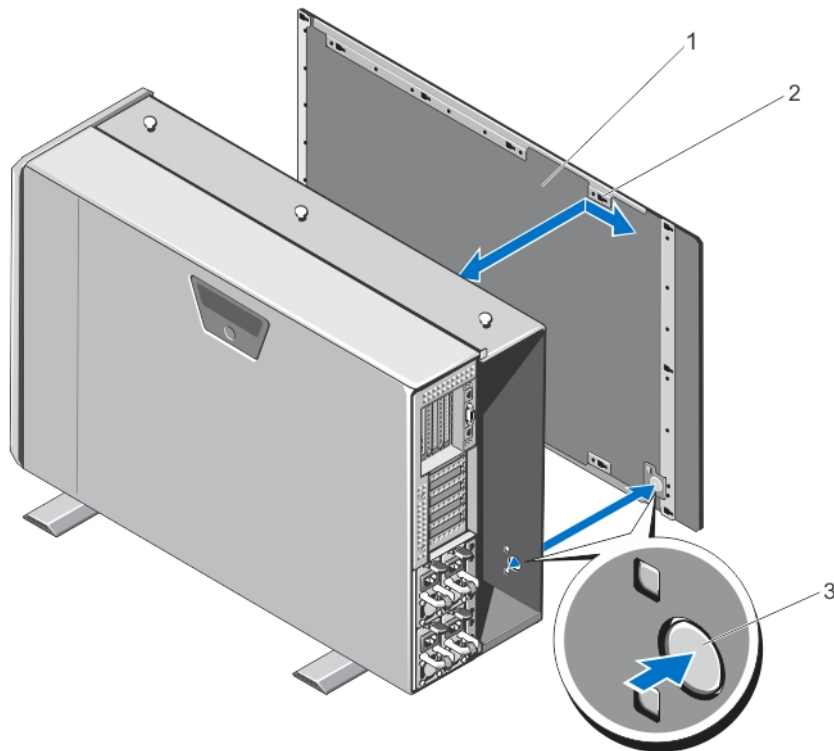
- Cartridge packages (consisting of two cartridges, screws and L-Key)
- #1 and #2 Phillips screwdrivers
- T6, T8, T10, T15, and T20 Torx drivers
- Wrist grounding strap

- 1 If installed, remove the front bezel.
- 2 Turn off the server modules using the operating system commands or the Chassis Management Controller (CMC).
- 3 Turn off the enclosure, including any attached peripherals, and disconnect the enclosure from the electrical outlet and peripherals.

- 4 Remove the following:
  - a server modules
  - b hard drives
  - c power supply units

**CAUTION:** The blower closeout door is spring loaded. To prevent injury, exercise care when placing your hand or fingers inside the blower module bay.

- d blower modules
  - e blower module bay
- 5 To remove the system side cover:
  - a Press the release button on the inside of the chassis wall, to disengage the side cover from the chassis.
  - b Slide the side cover toward the back of the system to disengage the cover hooks from the chassis, and remove the cover away from the chassis.



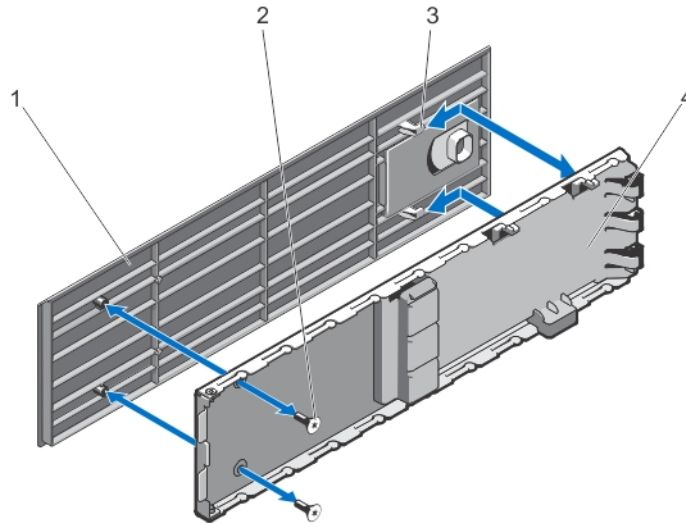
**Figure 90. Removing and installing the system side cover**

- 1 system side cover
- 2 hooks on the system side cover (15)
- 3 release button

- 6 Rotate the system feet inward and lay the system on its side on a flat, stable surface with the cover release latch side on top.

**NOTE:** For systems installed with the wheel assembly, ensure that you lay the system on its side on a flat, stable surface with the wheel assembly extending off the edge of the surface.

- 7 If installed, remove the wheel assembly and power cable retention bracket.
- 8 Remove the system base cover.
- 9 Open the system.
- 10 Remove the PCIe cage door.
- 11 To remove the PCIe cage door cover:
  - a Remove the two screws securing the PCIe cage door cover to the cage door.
  - b Slide the cage door cover out of the cage door.



**Figure 91. Removing and installing the PCIe cage door cover**

- |   |                             |   |                |
|---|-----------------------------|---|----------------|
| 1 | PCIe cage door cover        | 2 | screws (2)     |
| 3 | hooks on the door cover (2) | 4 | PCIe cage door |

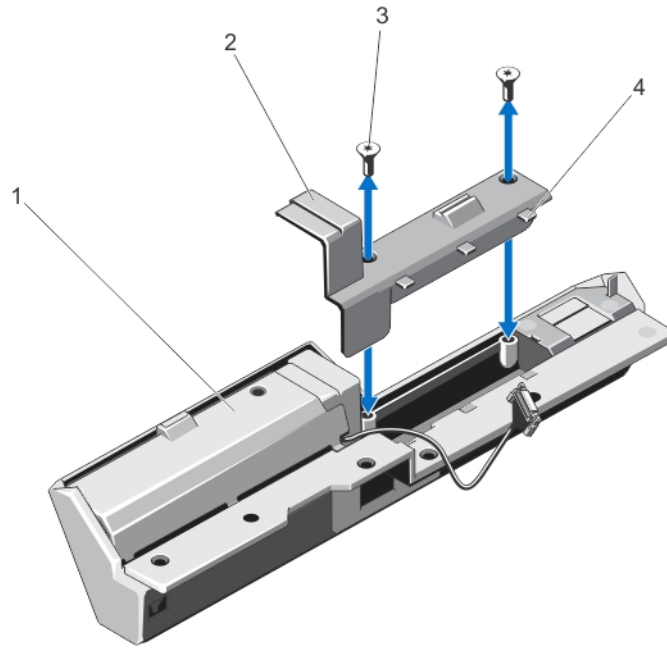
12 Remove the following:

- a system top cover
- b cooling shroud
- c cooling fan assembly
- d control panel
- e top and bottom mounting ears

13 To convert the top mounting ear to rack left ear:

- a Remove the screws securing the ear cover to be replaced by the cartridge, and remove the cover.
- b Align the tabs on the cartridge with the slots in the ear, and lower the cartridge until firmly seated. When properly seated, the screw holes on the other end of the cartridge align with the screw holes on the ear.
- c Attach the two screws to secure the cartridge to the ear.

**⚠ CAUTION: Take care while installing the cartridge, to prevent the LCD module cable from being pinched or crimped.**



**Figure 92. Converting the top mounting ear to left rack ear**

1 ear cover

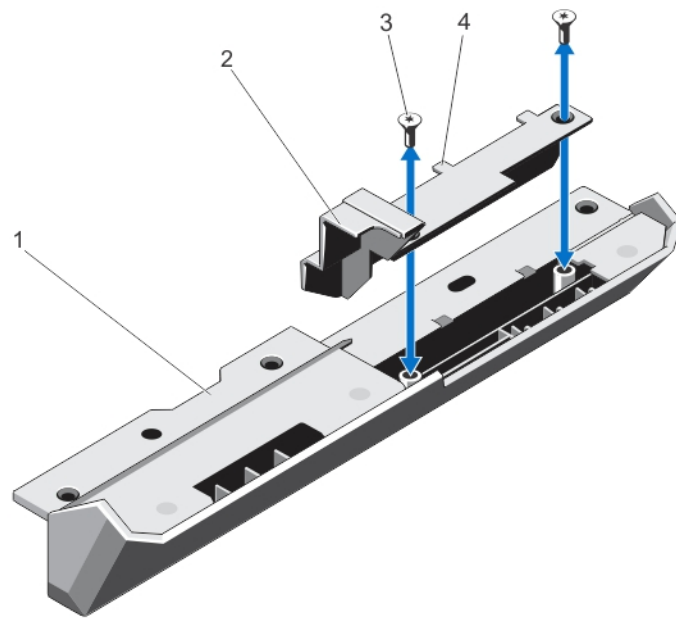
3 screws (2)

2 cartridge

4 tabs on cartridge (3)

14 To convert the bottom mounting ear to rack right ear:

- a Remove the screws securing the ear cover to be replaced by the cartridge, and remove the cover.
- b Align the tabs on the cartridge with the slots in the ear, and lower the cartridge until firmly seated.  
When properly seated, the screw holes on the other end of the cartridge align with the screw holes on the ear.
- c Attach the two screws to secure the cartridge to the ear.



**Figure 93. Converting the bottom mounting ear to right rack ear**

- |   |              |   |                       |
|---|--------------|---|-----------------------|
| 1 | mounting ear | 2 | cartridge             |
| 3 | screws (2)   | 4 | tabs on cartridge (2) |

The mounting ears are converted to rack ears.

- 15 Attach the rack ears to the chassis. See [Installing The Mounting Ears](#).
- 16 Reinstall the following:
  - a control panel
  - b cooling fan assembly
  - c cooling shroud
  - d PCIe cage door
- 17 Close the system.
- 18 Reinstall the following:
  - a blower module bay
  - b blower modules
  - c hard drives
  - d server modules
- 19 Reconnect the enclosure to its electrical outlet and turn the enclosure on, including any attached peripherals.
- 20 Turn on the server modules using the operating system commands or the CMC.
- 21 If applicable, install the front bezel.

## Installing the enclosure in a rack

To install the enclosure in a rack, see the rack documentation that shipped with your rack solution.



# Troubleshooting your system

**NOTE:** This chapter provides troubleshooting information for the VRTX enclosure only. For troubleshooting information on the server modules, see the server module documentation at [Dell.com/poweredge/manuals](http://Dell.com/poweredge/manuals).

## Safety first—for you and your system

**CAUTION:** Many repairs may only be done by a certified service technician. You should only perform troubleshooting and simple repairs as authorized in your product documentation, or as directed by the online or telephone service and support team. Damage due to servicing that is not authorized by Dell is not covered by your warranty. Read and follow the safety instructions that are shipped with your product.

Topics:

- [Responding to a systems management alert message](#)
- [Troubleshooting external connections](#)
- [Troubleshooting a damaged enclosure](#)
- [Troubleshooting enclosure components](#)

## Responding to a systems management alert message

The Chassis Management Controller (CMC) management applications monitor critical system voltages and temperatures, and the cooling fans in the system. For information about the CMC alert messages, see the *Dell Chassis Management Controller for Dell PowerEdge VRTX User's Guide* at [Dell.com/esmmanuals](http://Dell.com/esmmanuals).

## Troubleshooting external connections

Ensure that all external cables are securely attached to the external connectors on your system before troubleshooting any external devices.

## Troubleshooting a damaged enclosure

- 1 Ensure that the following components are properly installed and connected:
  - Server modules
  - Power supply units
  - Blower modules
  - I/O module
  - Cooling shroud
  - Cooling fans
  - Cooling fan assembly
  - CMC cards
  - Expansion cards
  - PCIe cage

- Enclosure hard drive carriers
  - Hard drive backplane
  - Backplane expander board
- 2 Ensure that all cables are properly connected.
  - 3 Ensure that all components are properly installed and free from damage.
  - 4 Run the online diagnostics.  
If the tests fail, see [Getting Help](#).

## Troubleshooting enclosure components

The following procedures describe how to troubleshoot the following components:

- Power supply unit modules
- Blower modules
- System battery
- Cooling fans
- Optical drive
- Storage controller card
- Expansion cards
- Hard drives
- I/O module

## Troubleshooting a wet enclosure

**⚠ CAUTION: Many repairs may only be done by a certified service technician. You should only perform troubleshooting and simple repairs as authorized in your product documentation, or as directed by the online or telephone service and support team. Damage due to servicing that is not authorized by Dell is not covered by your warranty. Read and follow the safety instructions that are shipped with your product.**

- 1 Turn off the system and attached peripherals.
- 2 Disconnect the power supply units (PSUs) from the PDU or electrical outlet.

**⚠ CAUTION: Wait until all of the indicators on the PSUs turn off before proceeding.**

- 3 Remove the following components from the system:
  - a Server modules
  - b PSUs
  - c Blower modules
  - d I/O module
  - e Enclosure hard drives
  - f Cooling shroud
  - g Cooling fan assembly
  - h Backplane expander board
  - i Hard drive backplane
  - j CMC cards
  - k PCIe cage
  - l Expansion cards

**⚠ CAUTION: Air dry and do not use towels.**

- 4 Let the system dry thoroughly for at least 24 hours.
- 5 Reinstall the components you removed in step 3.
- 6 Reconnect the PSUs to the PDU or electrical outlet and start up the system.  
If the system does not start up properly, see [Getting Help](#).

# Troubleshooting power supply units

**⚠ CAUTION:** The power supply units (PSUs) are hot swappable. Remove and replace only one PSU at a time in a system that is turned on. Leave a failed PSU installed in the enclosure until you are ready to replace it. Operating the system with a PSU removed for extended periods of time can cause the system to overheat.

**ⓘ NOTE:** Ensure that all PSUs are of the same rated output capacity, generation, and input voltage.

**ⓘ NOTE:** The VRTX chassis supports only PSUs with a rated output capacity of 1100 W or 1600 W.

- 1 Locate the faulty PSU and check the indicators. The PSU's AC indicator is green if AC power is available. The PSU's fault indicator is amber if the PSU is faulty. If no indicators are lit, ensure that AC power is available from the PDU or electrical outlet, and that the power cable is properly connected to the PSU.
- 2 Reseat the PSU by removing and reinstalling it.  
**ⓘ NOTE:** After installing a PSU, allow several seconds for the system to recognize the PSUs and determine whether it is working properly.
- 3 If the problem is not resolved, swap or replace the PSU with a known good PSU.
- 4 If none of the PSUs show a fault LED and the server modules do not turn on, check the LCD display or CMC for status messages. For more information, see the *Dell Chassis Management Controller for Dell PowerEdge VRTX User's Guide* at [Dell.com/esmanuals](http://Dell.com/esmanuals).
- 5 If the problem persists, see [Getting Help](#).

# Troubleshooting power supply unit mismatch

The PowerEdge VRTX chassis unit supports various power supply unit (PSU) models. Instances of PSU mismatch may occur when mixing different PSU models in a system configuration.

- 1 The system checks for a PSU mismatch following an AC power cycle or when a replacement PSU is connected.
- 2 The LED indicator in the handle of the PSU flashes green several times then turns off, this sequence indicates that there is a PSU mismatch.  
**ⓘ NOTE:** A critical alert message is generated in the chassis management controller (CMC) logs. The log provides information on the PSU redundancy status and the log also indicates if the PSU is incompatible with the other installed PSUs.
- 3 Replace the incompatible PSU with a known good PSU.
- 4 If the problem persists, see [Getting Help](#).

# Troubleshooting blower modules

**⚠ CAUTION:** The blower modules are hot swappable. Remove and replace only one blower module at a time in a system that is turned on. Operating the system without all four blower modules for extended periods of time can cause the system to overheat.

- 1 Locate the faulty blower module using the back panel blower module indicators.
- 2 Remove the blower module.
- 3 Examine the server modules for debris. If debris is present, carefully remove it.
- 4 Reseat the faulty blower module.
- 5 If the problem is not resolved, install a new blower module.
- 6 If the new blower module does not operate, see [Getting Help](#).

# Troubleshooting the system battery

**CAUTION:** Many repairs may only be done by a certified service technician. You should only perform troubleshooting and simple repairs as authorized in your product documentation, or as directed by the online or telephone service and support team. Damage due to servicing that is not authorized by Dell is not covered by your warranty. Read and follow the safety instructions that are shipped with your product.

- 1 Check the LCD screen for error messages indicating a defective system battery.
- 2 Turn off the system and disconnect it from the electrical outlet.
- 3 Replace the battery.
- 4 Log in to the CMC web interface and re-enter the time and date. For more information, see the *Dell Chassis Management Controller for Dell PowerEdge VRTX User's Guide* at [Dell.com/esmmanuals](http://Dell.com/esmmanuals).
- 5 Reconnect the system to the electrical outlet and turn on the system.

If the problem is not resolved by replacing the battery, see [Getting Help](#).

# Troubleshooting cooling problems

**CAUTION:** Many repairs may only be done by a certified service technician. You should only perform troubleshooting and simple repairs as authorized in your product documentation, or as directed by the online or telephone service and support team. Damage due to servicing that is not authorized by Dell is not covered by your warranty. Read and follow the safety instructions that are shipped with your product.

Ensure that the following conditions exist:

- System cover, cooling shroud, hard drive blank(s), server module blank(s), power supply unit blank(s), or expansion card filler bracket(s) is not removed.
- Ambient temperature is not too high.
- External airflow is not obstructed.

**NOTE:** To maintain optimum thermal conditions, ensure that there are no obstructions to airflow on the front and back of the enclosure. The front and back of the enclosure must have at least 30 cm (12-inches) and 61 cm (24-inches) of unobstructed space respectively.

- A blower module is not removed or has not failed.
- A cooling fan is not removed or has not failed.
- The expansion card installation guidelines are followed.

# Troubleshooting cooling fans

**CAUTION:** Many repairs may only be done by a certified service technician. You should only perform troubleshooting and simple repairs as authorized in your product documentation, or as directed by the online or telephone service and support team. Damage due to servicing that is not authorized by Dell is not covered by your warranty. Read and follow the safety instructions that are shipped with your product.

- 1 Log in to the CMC interface and identify the faulty fan. For more information, see the *Dell Chassis Management Controller for Dell PowerEdge VRTX User's Guide* at [Dell.com/esmmanuals](http://Dell.com/esmmanuals).
- 2 Open the system.
- 3 Reseat the fan.
- 4 If the fan functions properly, close the system.
- 5 If the fan does not function, install a new fan.
- 6 Close the system.

If the replacement fan does not operate, see [Getting Help](#).

## Troubleshooting an optical drive

**CAUTION:** Many repairs may only be done by a certified service technician. You should only perform troubleshooting and simple repairs as authorized in your product documentation, or as directed by the online or telephone service and support team. Damage due to servicing that is not authorized by Dell is not covered by your warranty. Read and follow the safety instructions that are shipped with your product.

- 1 Turn off the system and attached peripherals, and disconnect the system from the electrical outlet.
  - 2 If installed, remove the front bezel.
  - 3 Open the system.
  - 4 Ensure that the interface cable is securely connected to the optical drive and to the system board connector.
  - 5 Ensure that a power cable is properly connected to the drive.
  - 6 If the optical drive functions properly, close the system and reconnect it to the electrical outlet.
  - 7 If the optical drive does not function properly, try using a different DVD.
  - 8 Map the DVD to the appropriate server module using the LCD screen. For more information about DVD mapping, see the *Dell Chassis Management Controller for Dell PowerEdge VRTX User's Guide* at [Dell.com/esmmanuals](http://Dell.com/esmmanuals).
- If the problem is not resolved, see [Getting Help](#).

## Troubleshooting a storage controller

**CAUTION:** Many repairs may only be done by a certified service technician. You should only perform troubleshooting and simple repairs as authorized in your product documentation, or as directed by the online or telephone service and support team. Damage due to servicing that is not authorized by Dell is not covered by your warranty. Read and follow the safety instructions that are shipped with your product.

**NOTE:** When troubleshooting the Shared PERC controller, also see the documentation for your operating system and the controller.

- 1 Open the system.
  - 2 Check the storage controller card indicators. If the power indicator blinks irregularly or the attention indicator blinks amber, it indicates a fault condition.
  - 3 Turn off the system and attached peripherals, and disconnect the system from the electrical outlet.
  - 4 Reseat the integrated storage controller card, SAS cables, and the storage controller battery.
  - 5 If the storage controller functions properly, close the system, reconnect it to the electrical outlet, and turn the system on.
  - 6 If the storage controller does not function properly, log in to the CMC web interface and view the properties of the storage controller. For more information, see the *Dell Chassis Management Controller for Dell PowerEdge VRTX User's Guide* at [Dell.com/esmmanuals](http://Dell.com/esmmanuals).
- If the problem is not resolved, see [Getting Help](#).

## Troubleshooting hard drives

**CAUTION:** Many repairs may only be done by a certified service technician. You should only perform troubleshooting and simple repairs as authorized in your product documentation, or as directed by the online or telephone service and support team. Damage due to servicing that is not authorized by Dell is not covered by your warranty. Read and follow the safety instructions that are shipped with your product.

**⚠ CAUTION:** This troubleshooting procedure can destroy data stored on the hard drive. Before you proceed, back up all the files on the hard drive, if possible.

- 1 Check the hard drive status/identification indicator to see if the drive is in fault condition. For more information, see [Hard-Drive Indicator Patterns](#).
- 2 Log in to the CMC web interface and view the properties of the hard drive to see the fault condition. For more information, see the *Dell Chassis Management Controller for Dell PowerEdge VRTX User's Guide* at [Dell.com/esmmanuals](http://Dell.com/esmmanuals).
- 3 Take the hard drive offline and wait until the hard drive indicator codes on the drive carrier signal that the drive may be removed safely, then remove and reseal the drive carrier in the enclosure.
- 4 Ensure that any required device drivers are installed and are configured correctly.

**📘 NOTE:** Installing a hard drive into another bay may break the mirror if the mirror state is optimal.

- 5 Remove the hard drive and install it in the other drive bay.
- 6 If the problem is resolved, reinstall the hard drive in the original bay.  
If the hard drive functions properly in the original bay, the drive carrier may have intermittent problems. Replace the drive carrier.  
If the problem persists, see [Getting Help](#).

## Troubleshooting expansion cards

**⚠ CAUTION:** Many repairs may only be done by a certified service technician. You should only perform troubleshooting and simple repairs as authorized in your product documentation, or as directed by the online or telephone service and support team. Damage due to servicing that is not authorized by Dell is not covered by your warranty. Read and follow the safety instructions that are shipped with your product.

**📘 NOTE:** When troubleshooting an expansion card, see the documentation for your operating system and the expansion card.

- 1 Run the appropriate diagnostic test from the server module.  
If the test fails, go to step 3.
- 2 Log in to the CMC web interface and view the PCIe properties and verify the following:
  - PCIe slots are assigned to the server modules.
  - Virtual adapters are assigned to the server modules.

For more information, see the *Dell Chassis Management Controller for Dell PowerEdge VRTX User's Guide* at [Dell.com/esmmanuals](http://Dell.com/esmmanuals).
- 3 Turn off the system and attached peripherals, and disconnect the system from the electrical outlet.
- 4 Open the system.
- 5 Ensure that each expansion card is firmly seated in its connector.
- 6 Close the system.
- 7 If the problem is not resolved, turn off the system and attached peripherals, and disconnect the system from the electrical outlet.
- 8 Open the system.
- 9 Remove all expansion cards installed in the system.
- 10 Close the system.
- 11 Run the appropriate diagnostic test from the server.  
If the tests fail, see [Getting Help](#).
- 12 For each expansion card you removed in step 9, perform the following steps:
  - a Turn off the system and attached peripherals, and disconnect the system from the electrical outlet.
  - b Open the system.
  - c Reinstall one of the expansion cards.
  - d Close the system.
  - e Run the appropriate diagnostic test.

If a problem is still indicated, see [Getting Help](#).

## Troubleshooting the I/O module

**NOTE:** To eliminate the possibility of a hardware problem with the module or its attaching devices, first ensure that the module is properly initialized and configured.

- 1 Check that the pass-through module or switch ports are cabled correctly.
- 2 Ensure that the network daughter cards/LOM cards on the server modules are mapped to the I/O module.
- 3 Verify that the switch or pass-through module is fully booted, and verify the switch's firmware revision and IP address.
- 4 Verify that the switch module has a valid IP address for the subnet. Verify using the ICMP **ping** command.
- 5 Check the network connector indicators on the network switch module:
  - If the link indicator displays an error condition, check all cable connections.
  - Try another connector on the external switch or hub.
  - If the activity indicator does not glow, replace the network switch module.
- 6 Using the switch management interface, verify the switch port properties. If the switch is configured correctly, back up the switch configuration and replace the switch. See the switch module documentation for details.
- 7 Ensure that the appropriate Network Daughter Card(s) (NDC) are installed in the server module(s). If the network link indicator on the server module is green, then the server module has a valid link to the I/O module.
- 8 Ensure that the appropriate operating system drivers are installed and that the protocol settings are configured to ensure proper communication.

For more information about troubleshooting I/O modules and network issues, see **Networking Guides** at [en.community.dell.com/techcenter/networking](https://en.community.dell.com/techcenter/networking).

## System board connectors

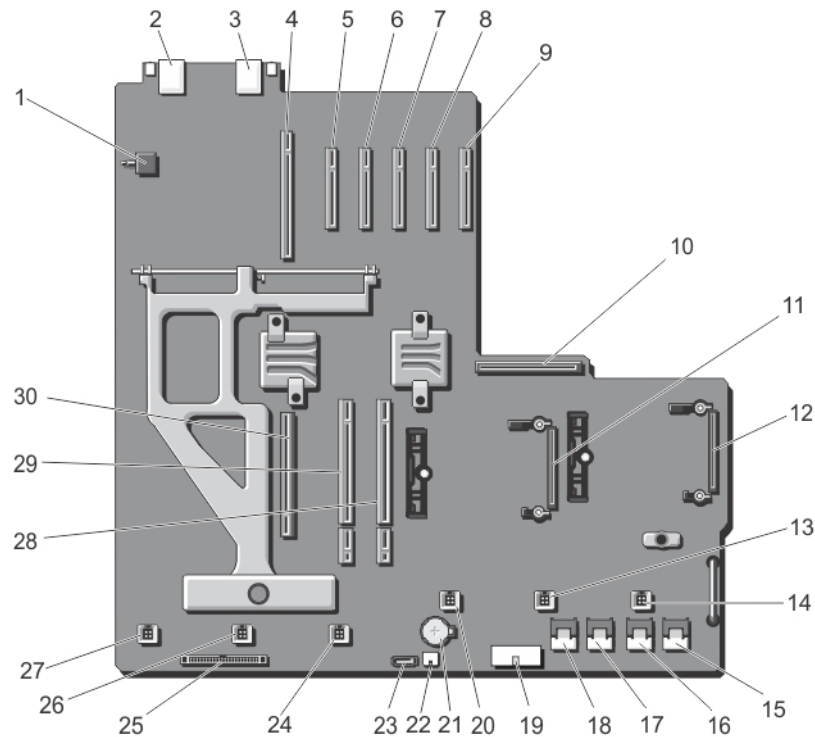


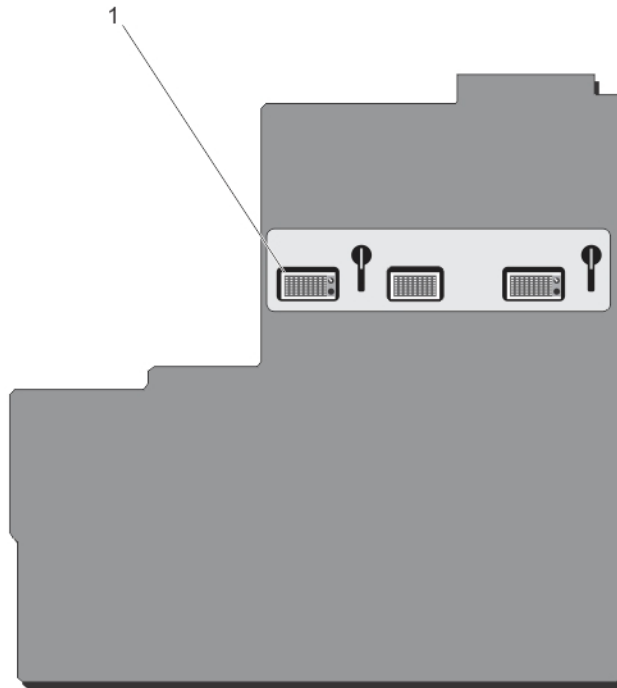
Figure 94. System board connectors

Table 10. System board connectors

Item	Connector	Description
1	SW2	Chassis intrusion switch
2	J_CMC1_RJ45	Ethernet port
3	J_CMC2_RJ45	Ethernet port
4	P_FH_RISER1	Expansion card riser connector
5	P_SLOT4_G2_X8_HP	Low profile expansion card connector
6	P_SLOT5_G2_X8_HP	Low profile expansion card connector
7	P_SLOT6_G2_X8_HP	Low profile expansion card connector
8	P_SLOT7_G2_X8_HP	Low profile expansion card connector
9	P_SLOT8_G2_X8_HP	Low profile expansion card connector
10	P_PSU_CONN	PDB connector
11	INT_STORAGE_1	Integrated storage controller card connector



<b>Item</b>	<b>Connector</b>	<b>Description</b>
12	INT_STORAGE_2	Integrated storage controller card connector
13	FAN 5	Cooling fan connector
14	FAN 6	Cooling fan connector
15	J_SAS_1A	SAS connector
16	J_SAS_1B	SAS connector
17	J_SAS_2A	SAS connector
18	J_SAS_2B	SAS connector
19	J_BP_PWR	Hard drive backplane power connector
20	FAN 4	Cooling fan connector
21	BAT	Battery connector
22	J_DVD_PWR	Optical drive power connector
23	J_DVD_SATA	Optical drive SATA connector
24	FAN 3	Cooling fan connector
25	J_CONTROL_PANEL	Control panel connector
26	FAN 2	Cooling fan connector
27	FAN 1	Cooling fan connector
28	P_CMC_2_X16	CMC card connector
29	P_CMC_1_X16	CMC card connector
30	P_FH_RISER2	Expansion card riser connector



**Figure 95. System board connectors (back)**

- 1 midplane planar connectors (3)

# Technical specifications

## Topics:

- [Enclosure dimensions and weight — Tower](#)
- [Enclosure dimensions and weight — Rack](#)
- [Server module specifications](#)
- [Expansion bus specifications](#)
- [Power specifications](#)
- [Drive specifications](#)
- [Chassis Management Controller specifications](#)
- [Enclosure control panel specifications](#)
- [I/O Module specifications](#)
- [Environmental specifications](#)
- [Expanded operating temperature](#)

## Enclosure dimensions and weight — Tower

Physical	Dimensions
Height	48.44 cm (19.07 inch) with system feet
	46.38 cm (18.26 inch) without system feet
Width	21.92 cm (8.62 inch) without system feet
	30.96 cm (12.18 inch) with system feet opened
Depth	72.98 cm (28.72) with or without bezel
Weight (maximum)	74.79 kg (164.88 lb)
Weight (empty)	31.70 kg (69.70 lb)

## Enclosure dimensions and weight — Rack

Physical	Dimensions
Height	21.92 cm (8.62 inch)
Width	44.63 cm (17.57 inch) without rack ears
	48.24 cm (19.0 inch) with rack ears
Depth	72.98 cm (28.72) with or without bezel
Weight (maximum)	68.72 kg (151.50 lb)
Weight (empty)	24.70 kg (54.45 lb)

# Server module specifications

## Server module Specification

**Model** Up to four PowerEdge M520, M620, or M630 server modules, or Up to two PowerEdge M820 server modules, or A mix of two PowerEdge M520, M620, or M630 server modules and one PowerEdge M820 server module.

**NOTE:** For more information about the technical specifications for the server modules, see the server module Owner's Manual at [Dell.com/poweredgemanuals](http://Dell.com/poweredgemanuals).

# Expansion bus specifications

## PCI Express expansion slots Specification

Slot 1	One standard height, full-length x8 PCIe Gen2 card slot connected to riser
Slot 2	One standard height, full-length x8 PCIe Gen2 card slot connected to riser
Slot 3	One standard height, full-length x8 PCIe Gen2 card slot connected to riser
Slot 4	One low profile, half-length x8 PCIe Gen2 card slot connected to system board
Slot 5	One low profile, half-length x8 PCIe Gen2 card slot connected to system board
Slot 6	One low profile, half-length x8 PCIe Gen2 card slot connected to system board
Slot 7	One low profile, half-length x8 PCIe Gen2 card slot connected to system board
Slot 8	One low profile, half-length x8 PCIe Gen2 card slot connected to system board


# Power specifications

## AC Power supply unit Specification

<b>Wattage</b>	1100 W 1600 W (800 W low line intended usage 100 – 127 V AC)
<b>Connector</b>	IEC C14
<b>Heat dissipation</b>	4100 BTU/hr (maximum for 1100 W power supply unit (PSU)) 3000 BTU/Hr (maximum for the 1600 W PSU de-rated to 800 W for low line operation) 6000 BTU/Hr (maximum for the 1600 W PSU for high line operation)
<b>System voltage requirements</b>	100 – 240 V AC, 50/60 Hz (1100 W PSU) 100 – 127 V AC, 50/60 Hz (1600 W PSU de-rated to 800 W) 200 – 240 V AC, 50/60 Hz (1600 W PSU)
<b>Battery</b>	3 V CR2032 Lithium coin cell

# Drive specifications

Drives	Specification
Controller type	Shared PERC 8
12 hard drive systems	Up to twelve 3.5-inch, hot-swappable SAS, SAS SSD, or Nearline SAS hard drives.
25 hard drive systems	Up to twenty-five 2.5-inch, hot-swappable SAS, SAS SSD, or Nearline SAS hard drives.
Optical drive	One optional SATA DVD-ROM drive or DVD+RW drive.

 **NOTE: DVD devices are data only.**

# Chassis Management Controller specifications

Externally accessible connectors	Specification
Remote management	Two dedicated 10/100/1000 Mb RJ-45 (for integrated Ethernet remote access controller).
Serial	9-pin, DTE, 16550-compatible

# Enclosure control panel specifications

Externally accessible connectors	Specification
USB	Two 4-pin, USB 2.0-compliant connectors for keyboard and mouse support
Video	15-pin VGA
LCD panel features	Four cursor control keys, one select key, LCD screen

# I/O Module specifications

 **NOTE: For more information about the technical specifications for the I/O modules, see the I/O module documentation at [Dell.com/poweredge/manuals](http://Dell.com/poweredge/manuals).**

# Environmental specifications

 **NOTE: For additional information about environmental measurements for specific system configurations, see [Dell.com/environmental\\_datasheets](http://Dell.com/environmental_datasheets).**

Temperature	Specifications
Continuous operation (for altitude less than 950 m or 3117 ft)	10 °C to 35 °C (50 °F to 95 °F) with no direct sunlight on the equipment.

## Temperature Specifications

**Maximum temperature gradient (operating and storage)** 20 °C/h (36 °F/h)

**Storage temperature limits** -40 °C to 65 °C (-40 °F to 149 °F)

## Relative humidity Specifications

**Storage** 5% to 95% RH with 33 °C (91 °F) maximum dew point. Atmosphere must be non-condensing at all times.

**Operating** 10% to 80% Relative Humidity with 26 °C (78.8 °F) maximum dew point.

## Maximum vibration Specifications

**Operating** 0.26 Grms at 5 Hz to 350 Hz (all operation orientations).

**Storage** 1.87 Grms at 10 Hz to 500 Hz for 15 min (all six sides tested).

## Maximum shock Specifications

**Operating** One shock pulse in the positive z axis of 31 G for 2.6 ms in all operational orientations.

**Storage** Six consecutively executed shock pulses in the positive and negative x, y, and z axes (one pulse on each side of the system) of 71 G for up to 2 ms.

## Maximum altitude Specifications

**Operating** 3,048 m (10,000 ft)

**Storage** 12,000 m (39,370 ft).

## Operating Altitude De-rating Specifications

**Up to 35 °C (95 °F)** Maximum temperature is reduced by 1 °C/300 m (1 °F/547 ft) above 950 m (3,117 ft).

**35 °C to 40 °C (95 °F to 104 °F)** Maximum temperature is reduced by 1 °C/175 m (1 °F/319 ft) above 950 m (3,117 ft).

**40 °C to 45 °C (104 °F to 113 °F)** Maximum temperature is reduced by 1 °C/125 m (1 °F/228 ft) above 950 m (3,117 ft).

The following section defines the limits to help avoid IT equipment damage and/or failure from particulates and gaseous contamination. If it is determined that levels of particulates or gaseous pollution are beyond the limits specified below and are the reason for the damage and/or failures to your equipment, it may be necessary for you to re-mediate the environmental conditions that are causing the damage and/or failures. Re-mediation of environmental conditions will be the responsibility of the customer.

## Particulate contamination Specifications

**Air filtration** Data center air filtration as defined by ISO Class 8 per ISO 14644-1 with a 95% upper confidence limit.

**NOTE:** Applies to data center environments only. Air filtration requirements do not apply to IT equipment designed to be used outside a data center, in environments such as an office or factory floor.

## Particulate contamination

### Specifications

**NOTE:** Air entering the data center must have MERV11 or MERV13 filtration.

## Conductive Dust

Air must be free of conductive dust, zinc whiskers, or other conductive particles.

**NOTE:** Applies to data center and non-data center environments.

## Corrosive Dust

- Air must be free of corrosive dust.
- Residual dust present in the air must have a deliquescent point less than 60% relative humidity.

**NOTE:** Applies to data center and non-data center environments.

## Gaseous contamination

### Specifications

## Copper coupon corrosion rate

<300 Å/month per Class G1 as defined by ANSI/ISA71.04-1985.

## Silver coupon corrosion rate

<200 Å/month as defined by AHSRAE TC9.9.

**NOTE:** Maximum corrosive contaminant levels measured at ≤50% relative humidity.

# Expanded operating temperature

**NOTE:** When operating in the expanded temperature range, system performance may be impacted.

**NOTE:** When operating in the expanded temperature range, ambient temperature warnings may be reported on the LCD and in the System Event Log.

## Expanded operating temperature

### Specifications

## < 10% of annual operating hours

5 °C to 40 °C at 5% to 85% RH with 26 °C dew point.

**NOTE:** Outside the standard operating temperature (10 °C to 35 °C), the system can operate down to 5 °C or up to 40 °C for a maximum of 10% of its annual operating hours.

For temperatures between 35 °C and 40 °C, de-rate maximum allowable dry bulb temperature by 1 °C per 175 m above 950 m (1 °F per 319 ft).

## < 1% of annual operating hours

–5 °C to 45 °C at 5% to 90% RH with 26 °C dew point.

**NOTE:** Outside the standard operating temperature (10 °C to 35 °C), the system can operate down to –5 °C or up to 45 °C for a maximum of 1% of its annual operating hours.

For temperatures between 40 °C and 45 °C, de-rate maximum allowable dry bulb temperature by 1 °C per 125 m above 950 m (1 °F per 228 ft).

## Expanded Operating Temperature Restrictions

- Do not perform a cold startup below 5 °C.
- The operating temperature specified is for a maximum altitude of 3050 m (10,000 ft).
- Four redundant power supply units are required.
- Non Dell qualified peripheral cards and/or peripheral cards greater than 25 W are not supported.

Expanded  
operating  
temperature

## Specifications

**NOTE:** For more information about the server module-specific restrictions for the expanded operating temperature range, see the technical specifications in the server module Owner's Manual at [Dell.com/poweredgemanuals](https://Dell.com/poweredgemanuals).



# Getting help

Topics:

- [Contacting Dell](#)
- [Quick Resource Locator](#)

## Contacting Dell

Dell provides several online and telephone-based support and service options. If you do not have an active internet connection, you can find contact information on your purchase invoice, packing slip, bill, or Dell product catalog. Availability varies by country and product, and some services may not be available in your area. To contact Dell for sales, technical assistance, or customer-service issues:

- 1 Go to **Dell.com/support**.
- 2 Select your country from the drop-down menu on the bottom right corner of the page.
- 3 For customized support:
  - a Enter your system Service Tag in the **Enter your Service Tag** field.
  - b Click **Submit**.The support page that lists the various support categories is displayed.
- 4 For general support:
  - a Select your product category.
  - b Select your product segment.
  - c Select your product.The support page that lists the various support categories is displayed.

## Quick Resource Locator

Use the Quick Resource Locator (QRL) to get immediate access to system information and how-to videos. This can be done by visiting **Dell.com/QRL** or by scanning a model specific QR code located on your Dell PowerEdge system using your smartphone. You can also

access your system information and how-to videos by scanning the following QR code.

